

UNIVERSAL

L A S E R S Y S T E M S I N C .

OEM CO₂ LASER
Integration Manual



March 2004

This publication and its contents are proprietary to Universal Laser Systems, Inc. (ULS), and are intended solely for the contractual use of ULS, Inc. customers.

While reasonable efforts have been made to assure the accuracy of this manual, ULS shall not be liable for errors contained herein or for incidental or consequential damage in connection with the furnishing, performance, or use of this material.

ULS reserves the right to revise this manual and make changes from time to time without obligation by ULS to notify any person of such revision or changes.

ULS does not assume any liability arising out of the application or use of any products, circuits, or software described herein. Neither does it convey a license under its patent rights nor the patent rights of others.

This publication and its contents may not be reproduced, copied, transmitted, or distributed in any form, or by any means, radio, electronic, mechanical, photocopying, scanning, facsimile, or otherwise, or for any other purpose, without the prior written permission of ULS.

Intended use of this product must be followed within the guidelines of this manual. In no event will ULS be liable for any damages caused, in whole or in part, by customer, or for any economic loss, physical injury, lost revenue, lost profits, lost savings or other indirect, incidental, special or consequential damages incurred by any person, even if ULS has been advised of the possibility of such damages or claims.

© 2004 Universal Laser Systems Inc. All Rights Reserved

WARNING: UNIVERSAL LASER SYSTEMS PRODUCTS ARE NOT DESIGNED, TESTED, INTENDED OR AUTHORIZED FOR USE IN ANY MEDICAL APPLICATIONS, SURGICAL APPLICATIONS, MEDICAL DEVICE MANUFACTURING, OR ANY SIMILAR PROCEDURE OR PROCESS REQUIRING APPROVAL, TESTING, OR CERTIFICATION BY THE UNITED STATES FOOD AND DRUG ADMINISTRATION OR OTHER SIMILAR GOVERNMENTAL ENTITIES.

SHOULD THE BUYER USE UNIVERSAL LASER SYSTEMS PRODUCTS FOR ANY SUCH UNINTENDED OR UNAUTHORIZED APPLICATION, ALL WARRANTIES REGARDING THE UNIVERSAL LASER SYSTEMS PRODUCTS SHALL BE NULL AND VOID. FURTHER, THE BUYER SHALL HAVE NO REMEDY AGAINST UNIVERSAL LASER SYSTEMS AND ITS OFFICERS, EMPLOYEES, SUBSIDIARIES, AFFILIATES AND DISTRIBUTORS FOR, AND THE BUYER SHALL INDEMNIFY AND HOLD THOSE PARTIES HARMLESS AGAINST, ANY AND ALL CLAIMS, COSTS, DAMAGES, EXPENSES AND REASONABLE ATTORNEY FEES ARISING OUT OF, DIRECTLY OR INDIRECTLY, ANY CLAIM ASSOCIATED WITH SUCH UNINTENDED OR UNAUTHORIZED USE, INCLUDING BUT NOT LIMITED TO ANY CLAIM BASED ON WARRANTY (EXPRESS OR IMPLIED), CONTRACT, TORT (INCLUDING ACTIVE, PASSIVE, OR IMPUTED NEGLIGENCE), STRICT LIABILITY, PATENT OR COPYRIGHT INFRINGEMENT OR MISAPPROPRIATION OF INTELLECTUAL PROPERTY.

The product described herein is covered under one or more of U.S. Patents 5,661,746; 5,754,575; 5,867,517; 5,881,087; 5,894,493; 5,901,167; 5,982,803; 6,181,719.



Table of Contents

Chapter 1

- (page) 2. Notice
4. 1.0 Introduction

Chapter 2

- 5-8. 2.0 Specifications

Chapter 3

9. 3.0 Safety Issues
9. 3.1 Laser Safety
9. 3.2 Electrical Safety
9. 3.3 Electromagnetic Interference
10. 3.4 Contacts for Safety Information

Chapter 4

10. 4.0 A Brief Description of the Laser

Chapter 5

- (page) 11. 5.0 UL OEM Laser Installation and Operation
11. 5.1 Laser Mounting
11. 5.1.1 Mounting Method One
11. 5.1.2 Mounting Method Two
13. 5.2 Electrical Connections
14. 5.3 Power Requirements
14. 5.4 Internal Fuse
14. 5.5 Interlock Circuit
15. 5.6 Laser Modulation
15. 5.7 Laser Tickle
16. 5.8 Laser Operational Signal
16. 5.9 Proper Airflow
17. 5.10 Ambient Temperature
17. 5.11 Laser Beam Output
19. 5.12 Laser Diode Specifications (Optional Accessory)

Chapter 6

19. 6.0 ULC OEM Combo Laser Installation and Operation
19. 6.1 Laser Mounting
20. 6.2 Electrical Connections
23. 6.3 Power Requirements
23. 6.4 Interlock Circuit
23. 6.5 Laser Modulation
24. 6.6 Laser Tickle
24. 6.7 Laser Operational Signal
25. 6.8 Proper Airflow
25. 6.9 Ambient Temperature
25. 6.10 Laser Diode Specifications (Optional Accessory)

Chapter 7

26. 7.0 Troubleshooting Tips
26. 7.1 Shipping Lasers Back for Repair or Refill



U L S

**16008 North 81st Street
Scottsdale, AZ 85260
Tele: 480.483.1214
Fax: 480.483.5620**



Thank you for choosing a Universal Laser Systems, Inc.

CO₂ laser for your application. ULS is committed to providing the marketplace with low cost CO₂ lasers, which take advantage of our patented technology to provide compact size, ease of integration and high performance. This integration manual will guide you through the process of installing a ULS laser into your equipment and provide you with the information you need to operate the laser. Please read this entire manual and familiarize yourself with its contents. If you need help, please feel free to call Universal Laser Systems and we will be happy to provide you with assistance.

Specifications

Specifications for all UL OEM CO₂ lasers are summarized below.

Parameter*	Model		
	UL-25-OEM UL-30-OEM	UL-35-OEM UL-40-OEM	UL-45-OEM UL-50-OEM UL-60-OEM
Rated Power**	25 or 30 W	35 or 40 W	45 or 50 W or 60W
Wavelength	10.6μ		
Power Stability	± 5% after 15 minutes of CW operation		
M ²	1.4 ± 0.2		
Beam Size (Near Field)	4 ± 1 mm		
Beam Divergence (Full Angle)	5 ± 1 mR		
Beam Ellipticity (Near Field)	1.4:1		
Polarization	Linear (Perpendicular to the laser base plate)		
Pointing Stability	200 μR		
Optical Pulse Rise or Fall Time	120 ± 40 μS		
Optical Modulation	100% up to 5 KHz		
Modulation Signal Type	TTL Compatible		
Internal Tickle	On/Off, Dipswitch Adj.		
Tickle Frequency	1-6 KHz		
Tickle Pulse Width	0-6 μS		
Cooling	Air (built-in)		
Weight	20 lbs. [9 kg]	23 lbs. [10.5 kg]	26 lbs. [12 kg]
Environmental			
Ambient Temperature***	50-95°F [10-35°C]		
Relative Humidity	< 90% (non-condensing)		
Power requirements			
DC Voltage	48.0 VDC		
RMS Current (CW, including fan)	10 A	14 A	18 A
Inrush Current	70 A, 150 μS		

* The specifications are subject to change without notice.

** Output power is guaranteed to exceed this level for a period of 15 months from the date of purchase, regardless of use.

*** At temperatures below 50°F [10°C] operation may be intermittent and there is a potential for damage to the power supply and optics.

Specifications

Specifications for all ULC OEM CO₂ combo lasers are summarized below.

Parameter*	Mode		
	ULC-60-OEM	ULC-70-OEM ULC-80-OEM	ULC-90-OEM ULC-100-OEM
Rated Power**	60 W	70 or 80 W	90 or 100 W
Wavelength	10.6μ		
Power Stability	± 5% after 15 minutes of CW operation		
M ²	1.2 ± 0.2		
Beam Size (Near Field)	4 ± 1 mm		
Beam Divergence (Full Angle)	5 ± 1 mR		
Beam Ellipticity (Near Field)	N/A		
Polarization	Random		
Pointing Stability	200 μR		
Optical Pulse Rise or Fall Time	120 ± 40 μS		
Optical Modulation	100% up to 5 KHz		
Modulation Signal Type	TTL Compatible		
Internal Tickle	On/Off, Dipswitch Adj.		
Tickle Frequency	1-6 KHz		
Tickle Pulse Width	0-6 μS		
Cooling	Air (built-in)		
Weight	65 lbs. [30 kg]	73 lbs. [33 kg]	81 lbs. [37 kg]
Environmental			
Ambient Temperature***	50-95°F [10-35°C]		
Relative Humidity	< 90% (non-condensing)		
Power requirements			
DC Voltage	48.0 VDC		
RMS Current (CW, including fan)	20 A	28 A	36 A
Inrush Current	140 A, 150 μS		

* The specifications are subject to change without notice.

** Output power is guaranteed to exceed this level for a period of 15 months from the date of purchase, regardless of use.

*** At temperatures below 50°F [10°C] operation may be intermittent and there is a potential for damage to the power supply and optics.

Dimensional Specifications

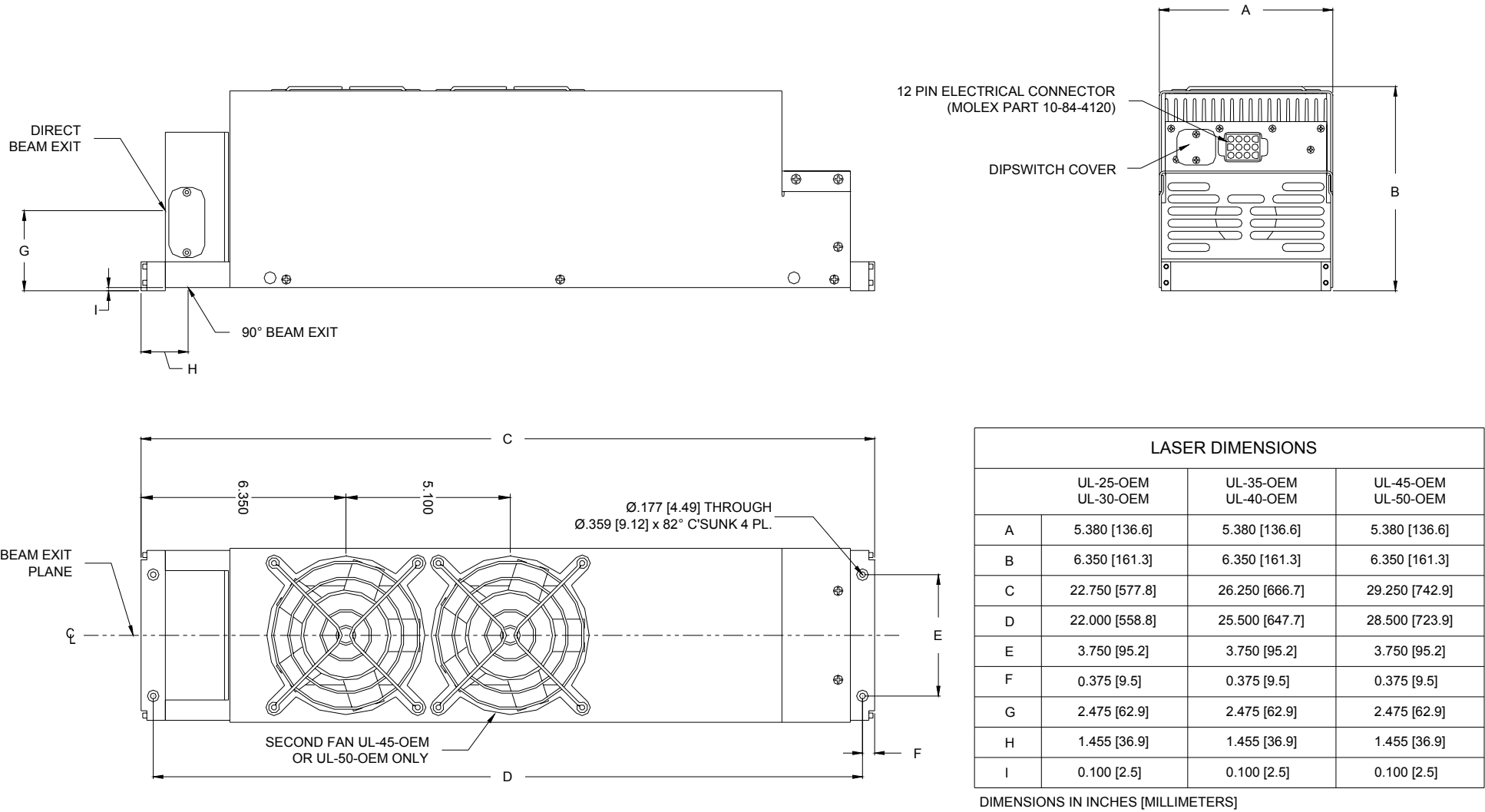

Figure 1

Dimensional Specifications

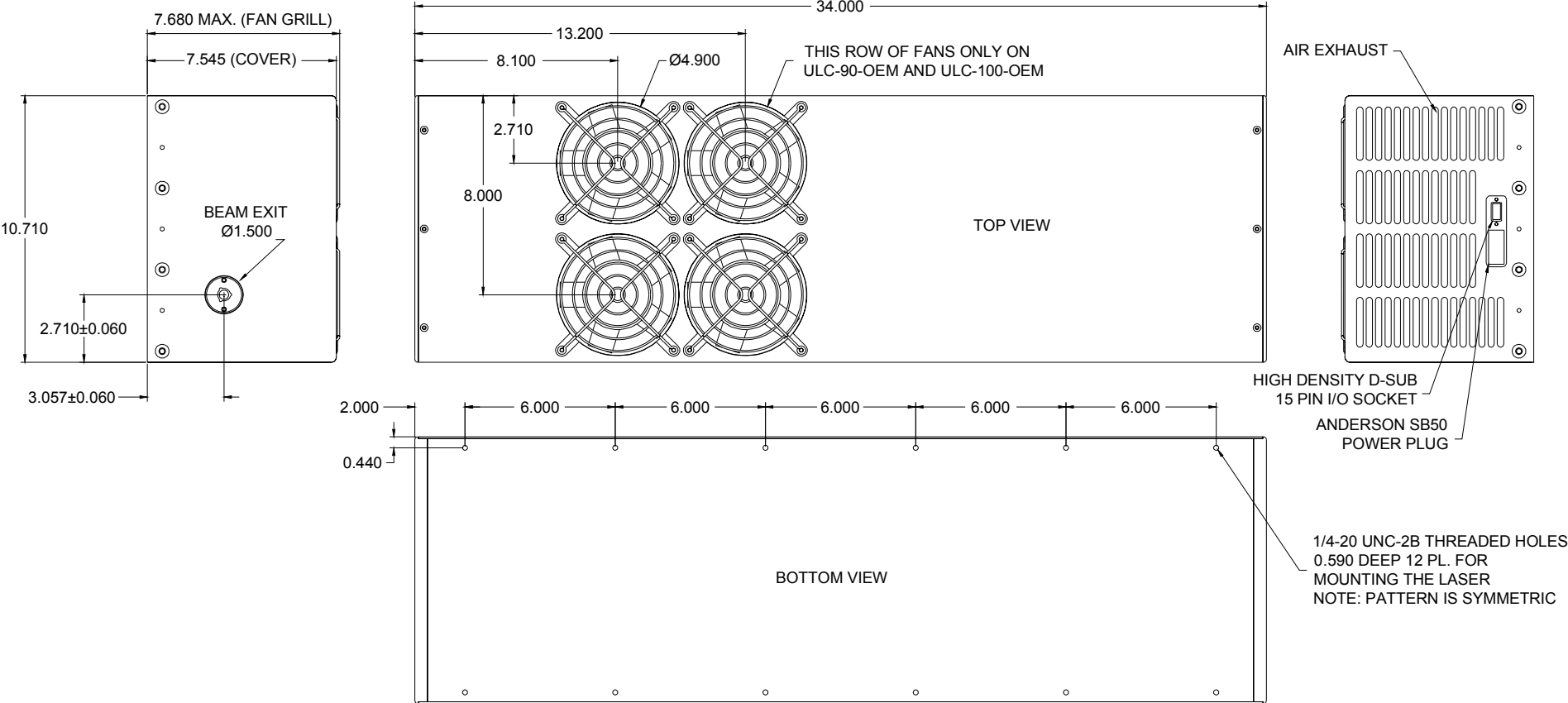

Figure 2

3.0 Safety Issues

3.1 Laser Safety

ULS OEM lasers are sold as components and therefore are not required to conform to U.S. or European safety regulations. It is the responsibility of the buyer to design and certify any equipment incorporating a ULS OEM laser to meet all local safety regulations prior to sale to the public. The texts of these regulations are available from the respective governing bodies of the countries the equipment is to be sold into. Any personnel working with or around open lasers must be aware of the following:

- Exposure to the laser beam may cause physical burns and can cause severe eye damage. Proper eye protection should be used at all times. All eye protection should be appropriate for the radiation wavelength generated by the laser in use.
- Exposure to the laser beam may cause ignition of volatile or combustible materials. Do not use lasers in the presence of these types of materials.
- Never look directly into the laser output port.
- Interlock all rooms in which open beams may be present and post appropriate warnings on or near the doors. Access to these rooms should be limited to properly trained technicians when lasers are in use.
- Use appropriate protective coverings over all beam paths whenever possible.
- Lasers and optical elements should be positioned to keep the beam and reflections below eye level.

Notice: For more information on EMI standards, refer to local EMI safety regulations.

ULS lasers are not designed, tested, intended or authorized for use in any medical applications, surgical applications, medical device manufacturing, or any similar procedure or process requiring approval, testing, or certification by the United States Food and Drug Administration or other similar governmental entities. Please see the Notice herein for further information regarding such uses

3.2 Electrical Safety

ULS lasers operate at 48 VDC, which is below the voltage limit that is considered dangerous by most safety standards. However, the lasers draw large amounts of current and the power supplies needed to provide the 48 VDC usually require 90-240 VAC to

operate. For these reasons, proper safety precautions should be taken with every portion of the electrical system.

Notice: For more information on EMI standards, refer to local EMI safety regulations.

3.3 Electromagnetic Interference

ULS OEM lasers are sold as components and therefore are not required to conform to all U.S. or European safety regulations regarding EMI. It is the responsibility of the customer to design and certify any equipment incorporating a ULS OEM laser to meet all local safety regulations prior to sale to the public. However, testing by ULS has demonstrated that with a properly selected power supply and line filtering, all ULS OEM lasers will pass the relevant U.S. and European EMI standards for Class A equipment. See Section 5.10 for more information.

Notice: For more information on EMI standards, refer to local EMI safety regulations.

3.4 Contacts for Safety Information

Below is a list of useful contacts for information on safety regulations in the U.S. Canada, and Europe:

United States

- Food and Drug Administration - Center for Devices and Radiological Health (CDRH), 1-800-638-2041.
- Federal Communications Commission (FCC), (301) 362-3000.
- Underwriters Laboratories Inc. (UL), Illinois (708) 272-8800, New York (516) 271.6200, California (408) 985-2400.
- Laser Safety Institute of America, (407) 380-1553.
- Occupational Safety and Health Administration (OSHA), (202) 693-2300.

Canada

- Canadian Standards Association (CSA), (416) 747-4000.

3.0 Safety Issues

3.4 Contacts for Safety Information (continued)

Europe

- European Committee for Electrotechnical Standardization (Cenelec), rue de Stassart 35, B-1050 Brussels.
- International Organization for Standardization (ISO), 1 rue de Varembé, Case postale 56, CH-1211 Genève 20 Switzerland.

4.0 A Brief Description of the Laser

UL OEM Lasers

All ULS OEM CO₂ gas lasers use a sealed-off, RF-excited, slab design and a multi-pass, free space resonator₁. Each laser consists of a plasma tube, with mirrors at each end forming an optical resonator, and an RF power supply assembled together in a chassis which includes an integrated cooling fan and convenient mounting provisions.

The plasma tube consists of two opposing electrodes in a slab configuration, meaning the cross-section of the gap between the electrodes is rectangular instead of square. This allows for a multi-pass resonator in which the laser beam makes several passes within the plasma using the full width of the rectangular electrode gap. The advantage of this is a powerful laser beam from a relatively short tube.

The length of the gap between the electrodes is designed to allow free space operation of the laser. This means that the gap is wide enough to allow the laser beam to form without any substantial waveguide effects caused by reflection of light from the surfaces of the electrodes. This provides for a very good quality beam in the near field as well as far field.

The optical resonator is formed by a system of three mirrors, one in the back and two in the front, with one front mirror being partially reflective to allow the beam to exit the tube. These mirrors are tuned to specific angles to generate multiple passes of the laser beam within the plasma formed between the electrodes.

Each electrode is attached to the RF power supply through a matching network that allows the impedance of the tube to be tuned to match the impedance of the supply. The RF power supply operates at approximately 40 MHz. Power control of the laser beam is provided through pulse width modulation of the RF by an external TTL signal provided by the user.

ULC OEM Combo Lasers

The combo line of lasers takes advantage of the linear polarization of the laser beams from two standard UL lasers to optically combine the beams. The two lasers are mounted together in a rigid housing and optically aligned so that the beams are collinear, creating a new laser product with double the power output of our standard single tube lasers. To combine the beams, the polarization vector and the ellipticity of one laser is rotated ninety degrees to that of the other and then both beams are directed through a combining element. This results in a combined beam that is randomly polarized with little to no ellipticity.

1 As described in U.S. Patent 5,661,746

5.0 UL OEM Laser Installation and Operation

5.1 Laser Mounting

There are two methods for mounting the laser. Method One is the easiest method and is recommended.

5.1.1 Mounting Method One

The fastest and easiest way to mount the laser is to use the included mounting blocks, one attached to either end of the base plate of the laser, as shown in Figure 3. Each mounting block incorporates two countersunk holes designed for #8 [4 mm] flat head socket screws. The minimum recommended length for the screws is 1.25 inches [32 mm]. The laser can be mounted in any orientation, including vertical. Dimensions for the mounting-hole pattern are given below. The laser should be mounted using a three-point arrangement to avoid warping or bowing the assembly. If the laser is mounted on a flat surface it should be flat to within 0.025 inches [0.65 mm].

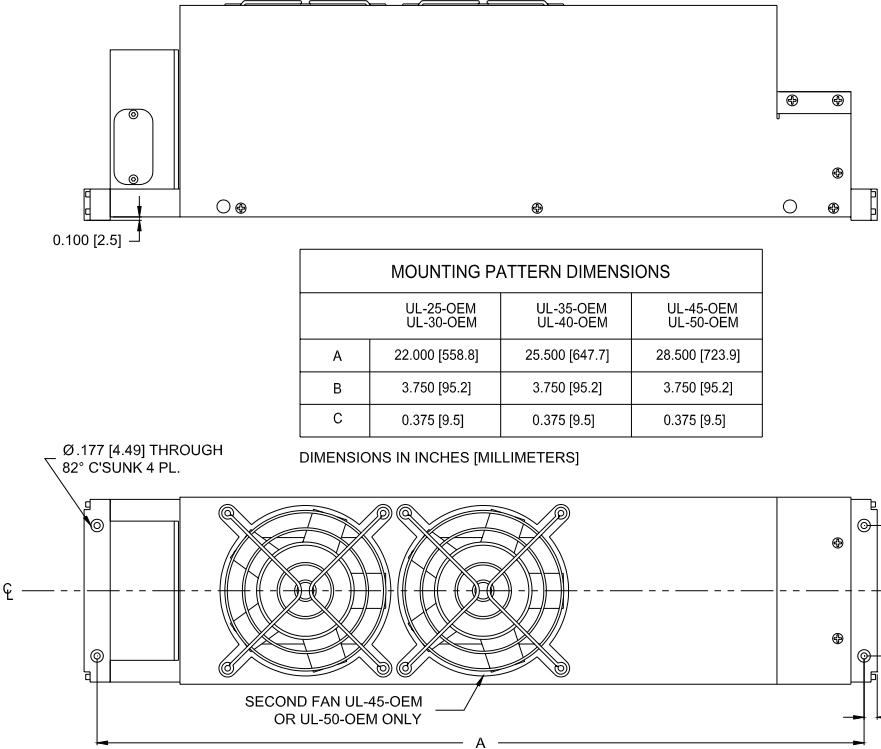

Figure 3 - Detail of mounting block dimensions

The included mounting blocks can also be modified or replaced to accommodate other mounting arrangements. Figure 4 provides the dimensions of the mounting block for reference. When implementing custom mounting arrangements, a gap of 0.100" [2.5 mm] should be maintained between any mounting surface and the base of the laser. This is to prevent any forces from bending or bowing.

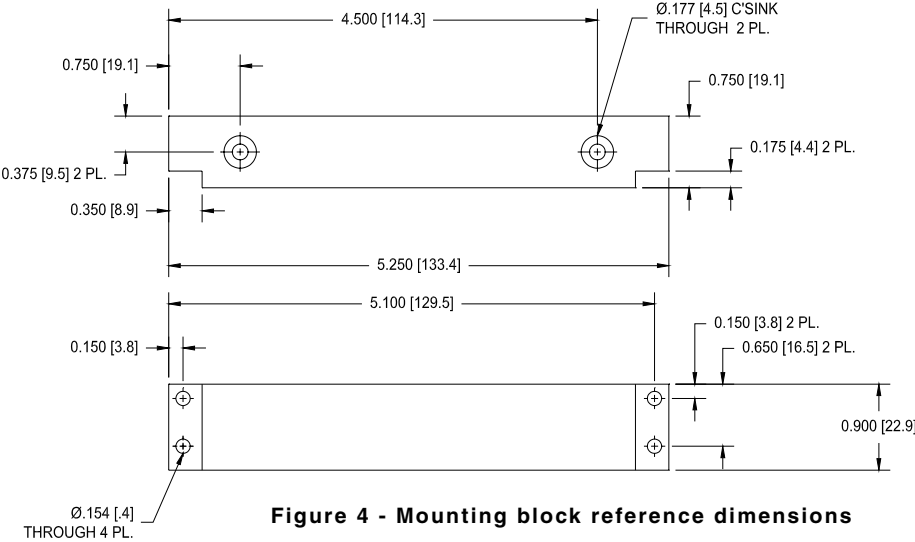

Figure 4 - Mounting block reference dimensions

5.1.2 Mounting Method Two

The base of the laser incorporates an extruded dovetail as shown in Figure 5, which can be used for mounting the laser to horizontal or vertical surfaces. A 0.375-inch [9.5 mm] diameter rod shape can be used to locate in one or both of the grooves to hold the laser. A ball shape is not recommended for location in the groove because the laser base material is aluminum and can be deformed easily. One example for mounting the laser vertically is shown in Figure 6. Many other configurations are possible.

5.0 UL OEM Laser Installation and Operation

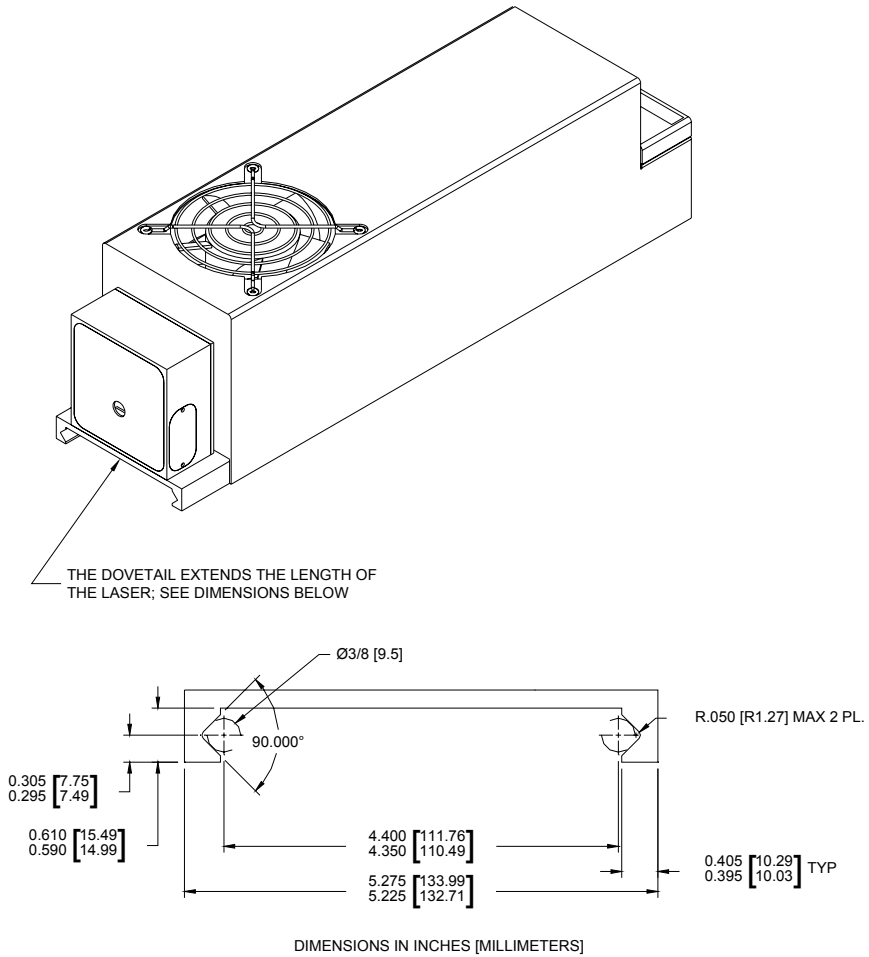

Figure 5 - Dovetail detail

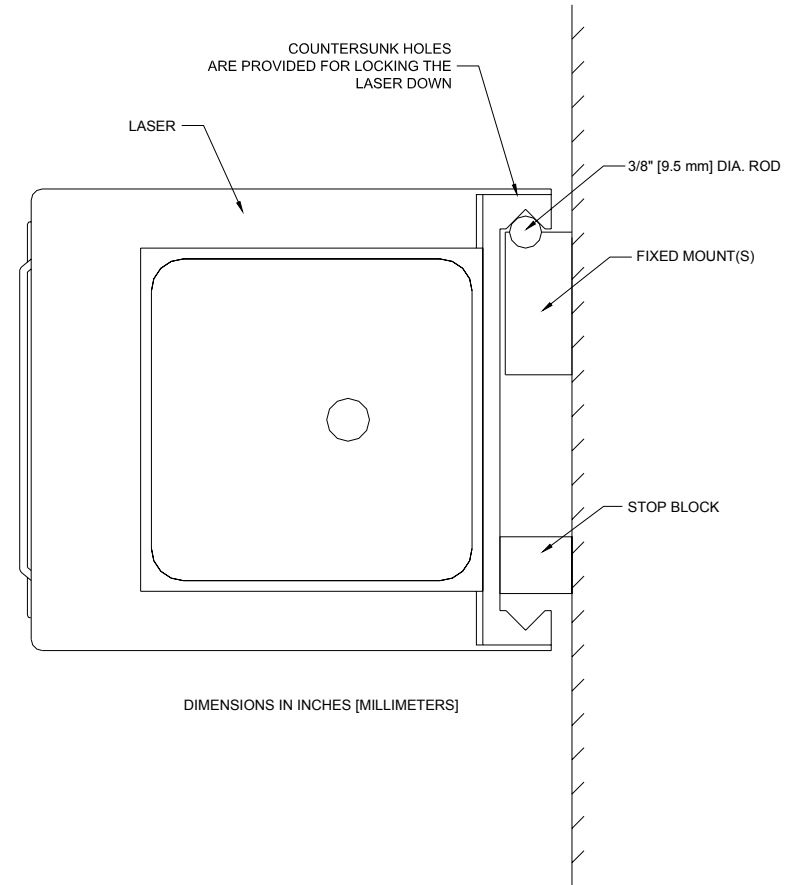

Figure 6 - Example of laser mounting using dovetail

5.0 UL OEM Laser Installation and Operation

5.2 Electrical Connections

All electrical connections for the laser are made through one twelve-pin connector located on the back of the laser. The mating connector will accommodate a combination of 14 AWG [2.0 mm²] wire for power and 22 AWG [0.30 mm²] wire for signals. Figure 7 below details the electrical characteristics of each of the pins in the connector. Figure 8 details the circuits inside the laser attached to the pins.

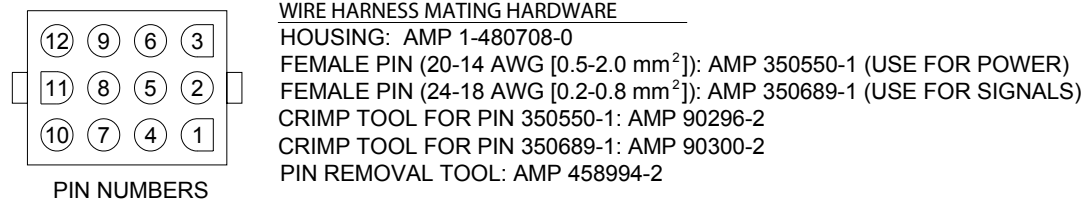

Figure 7 – Laser connector pin diagram

Pin Number	Input Name	Laser Input/Output	Wire Size	Description
1 & 4	+48V	Power input	14 AWG [2.0 mm ²]	+48 volt power; do not swap polarity.
2	Reserved	Does not use		Reserved for future use.
3	Laser Operational	Optically isolated output	22 AWG [0.30 mm ²]	Optional indicator requires an external +5V source and 470 ohm current-limiting resistor between pins 3 and 9. The optoisolator will activate if the laser has power and the temperature is within limits. The optoisolator will remain open if the laser does not have power, is not connected, or the temperature is out of range.
5	Interlock sense	Interlock input	22 AWG [0.30 mm ²]	+12 volt source applied to this pin enables RF power generation to laser. Intended to be used with safety switches. Do not modulate laser with this signal. See pin 8 for connection info.
6	Modulation +	Optically isolated input	22 AWG [0.30 mm ²]	Laser modulation signal is connected between pins 6 and 9.
7 & 10	Ground	Power input	14 AWG [2.0 mm ²]	Power ground.
8	+12V	12 volt source (only use for interlock)	22 AWG [0.30 mm ²]	Connect safety switches between pins 8 and 5 to enable laser. Do not use this pin as a power source for other purposes.
9	Return	Optoisolator return signal	22 AWG [0.30 mm ²]	Optically isolated return signal for “Modulation +” (pin 6), “Laser Diode” (pin 11), laser status (pin 3).
11	Laser Diode	Optically isolated input	22 AWG [0.30 mm ²]	+5V signal between pins 11 and 9 will turn on red laser pointer (if equipped).
12	Reserved	Does not use		Reserved for future use.

5.0 UL OEM Laser Installation and Operation

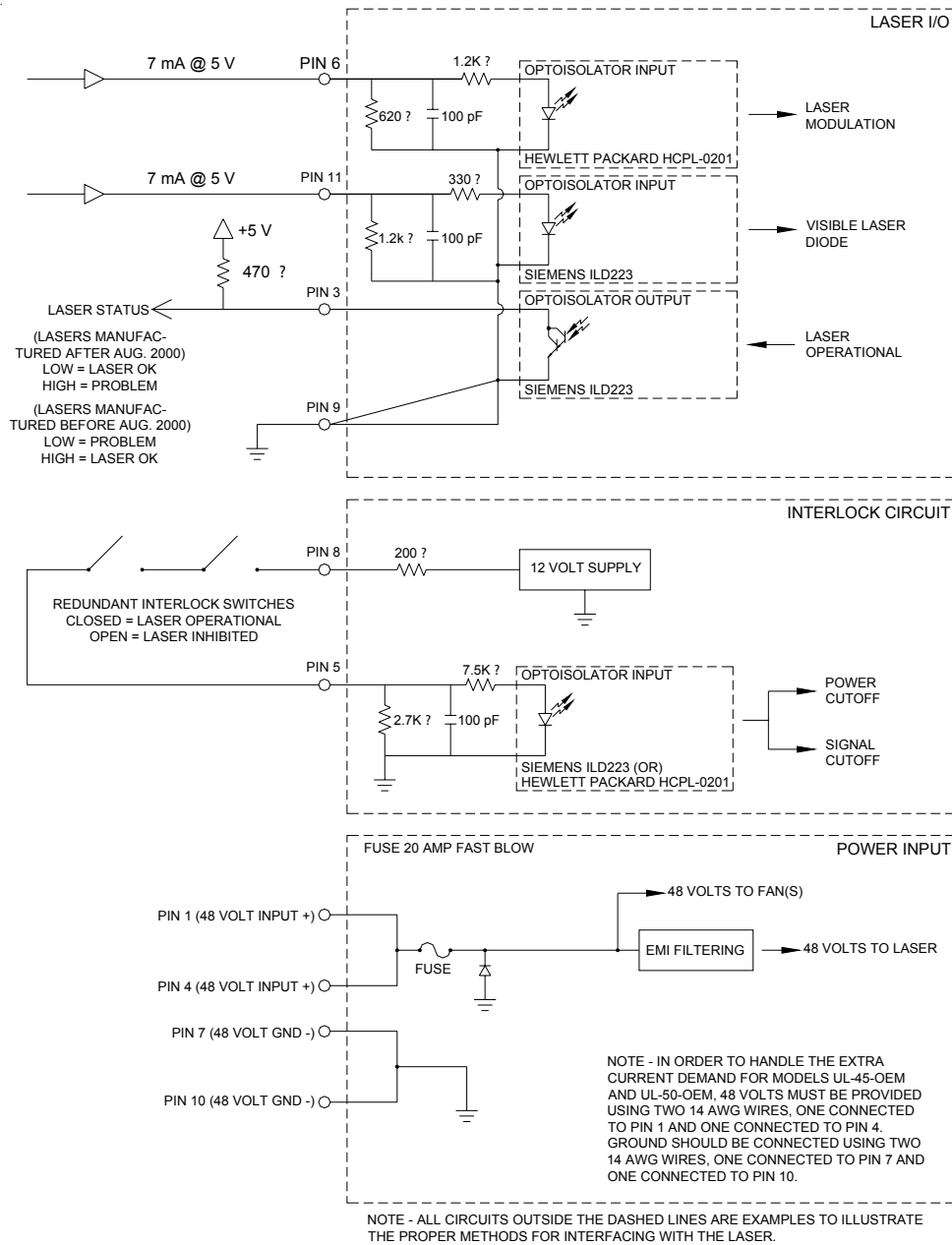

Figure 8 - Laser interconnect schematic

5.3 Power Requirements

A good quality 48 volt DC power supply should be used to power the laser. Nominal output should not exceed 48 volts and regulation should be within 0.5% under 100% load. The power supply should have good transient response characteristics to handle the fluctuating current requirements caused by modulation of the laser. The power and signal connector provides two pins each for 48 volt and ground connections to the power supply. A single 14 AWG [2.0 mm²] wire each is sufficient for 48 volts and ground on laser models UL-25-OEM, UL-30-OEM, UL-35-OEM and UL-40-OEM, but two 14 AWG [2.0 mm²] wires each are required for 48 volts and ground on laser model UL-45-OEM and UL-50-OEM in order to handle the extra current requirements. Careful attention should be paid to power entry filtering when designing to meet Class A conducted EMI regulations. In order to meet Class A emitted EMI regulations, it is important that the 48 volt power wires be no more than 3 feet (1 meter) in length and that the 48 volt power supply and laser chassis be attached to a common earth ground through very low induction connections.

5.4 Internal Fuse

All ULS lasers have a built in fuse for the 48 volt power source. This fuse also acts as protection in the event that the 48 volts and ground are cross-wired. If the fuse fails, it must be replaced with another fast blow fuse of the same rating. The fuse holder will accept both 3/4" and 20 mm fuses. It is important to identify and correct the cause of the failure before replacing the fuse. The main sheet metal cover must be removed to access the fuse holder, which is located near the connector.

5.5 Interlock Circuit

An interlock circuit is incorporated into the laser, which can be combined with external switches to satisfy safety requirements when designing Class 1 laser equipment. At least two redundant switches must be used for each panel providing access to a Class 1 enclosure. Please refer to the appropriate safety regulations for more information on Class 1 laser equipment design.

The interlock circuit is self-sourced using a 12 volt output supplied by the laser on pin 8. The interlock is shunted by connecting pin 8 to pin 5 allowing the laser to operate. Any break in this connection will cause the laser to stop operating. Switches can be placed in series with these pins to create a safety interlock circuit.

5.0 UL OEM Laser Installation and Operation

5.6 Laser Modulation

A TTL compatible signal must be provided to pin 6 of the power and signal connector to drive the laser. Output power can be controlled from 0 to 100% (CW Mode) by pulse width modulation of the input signal. The electrical requirements for the modulation signal are as follows:

- Nominal Voltage: 5 Volt (7 volts max)
- Current: 7 mA Min
- Logic High: 2.70 Volts Min
- Logic Low: 1.725 volts Max

As with all CO₂ lasers, delays are inherent in the response of the laser beam output to the input signal. A typical laser will have response characteristics similar to those detailed in the oscilloscope traces in figures 9 and 10. These figures show a TTL signal and corresponding laser power output.

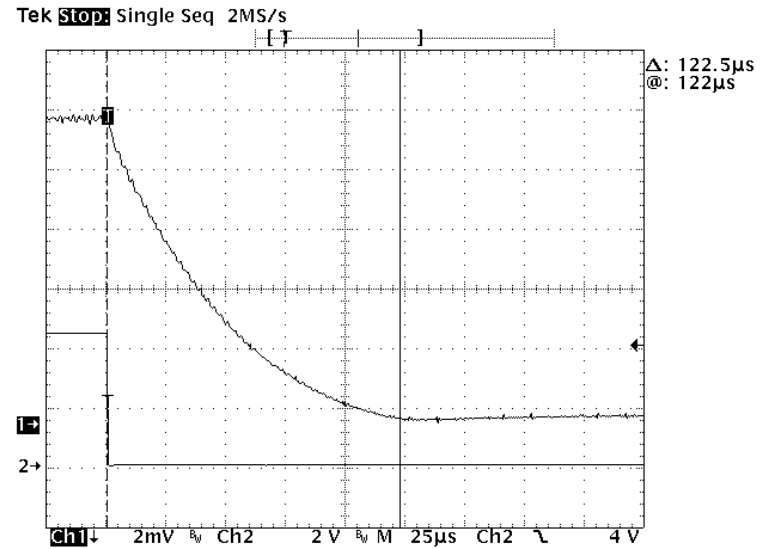

Figure 10 – Oscilloscope trace of typical fall time for a laser

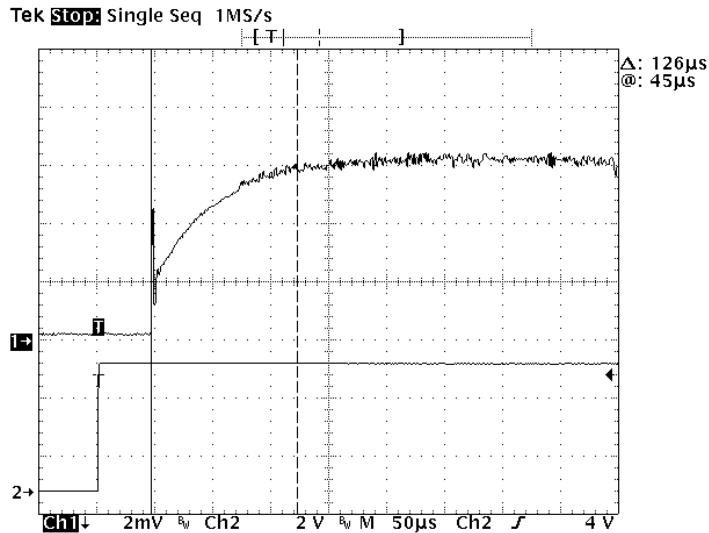

Figure 9 – Oscilloscope trace of typical rise time for a laser

5.7 Laser Tickle

It is a common practice with CO₂ lasers to provide some means of stimulating the mixture when the laser is off in order to improve its response. ULS lasers have a built-in, low duty cycle, secondary modulation signal called a tickle signal to accomplish this effect. This signal is pre-tuned at the factory for optimal performance of the laser and normally does not require adjustment. However, as a laser ages, the pulse width and/or frequency of this signal may need to be increased. This should only be done with authorization of the ULS service department. If the tickle signal needs adjusting, it can be changed using the dipswitches according to figure 11. If the tickle must be modified, it will be necessary to remove the dipswitch cover near the connector on the laser, (see figure 1 for the location of the dipswitch cover).

5.0 UL OEM Laser Installation and Operation

1 2 3		4 5 6		7	8		
TICKLE FREQUENCY			TICKLE WIDTH			RESERVED	RESERVED
000	5.8 KHz	000	0.8 μ S	"Reserved" must be in the ON position. Damage to the laser will result if turned off.	"Reserved" must be in the ON position. Damage to the laser will result if turned off.		
001	5.1 KHz	001	1.5 μ S				
010	4.5 KHz	010	2.7 μ S	Warning: An improperly set tickle signal can cause the laser to produce a continuous beam.	0= switch OFF 1=switch ON		
011	4.1 KHz	011	3.3 μ S				
100	3.5 KHz	100	4.1 μ S				
101	3.2 KHz	101	4.9 μ S				
110	3.0 KHz	110	5.6 μ S				
111	2.8 KHz	111	6.0 μ S				

Figure 11 – Detail of dipswitch showing tickle configuration

5.8 Laser Operational Signal

A "laser operational" signal is provided on pin 3 of the power and signal connector for diagnostic purposes. This signal will function in one of two ways depending on the date of manufacture.

Lasers manufactured before August 2000:

To read the signal, an external +5V source must be provided through a 470 ohm current-limiting resistor to pin 3, and the +5V source's ground connected to pin 9 (the optically-isolated "return" pin.) The optoisolator will remain open (thus pin 3 will be high) if the temperature is within limits. The optoisolator will activate (thus shunting pin 3 low) if the temperature is out of range.

Lasers manufactured after August 2000:

To read the signal, an external +5V source must be provided through a 470 ohm current-limiting resistor to pin 3, and the +5V source's ground connected to pin 9 (the optically-isolated "return" pin.) The optoisolator will activate (thus shunting pin 3 low) if the laser has power and the temperature is within limits. The optoisolator will remain open (thus pin 3 will be high) if the laser does not have power, or is not connected.

Note: For diagnostic purposes, the condition of the laser operational signal can be checked with a multi-meter without the use of a power source and pull-up resistor. Measure the resistance between pins 9 and 3 using the resistance function of the multi-meter. Make sure that the black (ground) lead is used on pin 9. An open circuit will measure infinite resistance and a closed circuit will measure between 100 and 500 Ohms. The interpretation of the open or closed circuit will depend on the date of manufacture of the laser as described above.

5.9 Proper Airflow

Careful attention should be paid to proper airflow through the laser (see figure 12) when integrating it into equipment. Any restriction of airflow will result in reduced power output and can cause permanent power loss or failure over extended periods of time. Ambient air should be directed to the laser's intake fan, and exhaust air from the laser should be directed out of equipment with as little restriction as possible. If the laser is placed in an enclosure, it may be necessary to provide additional fans to draw exhaust air out of the enclosure in order to prevent a rise in temperature inside the enclosure, which can affect laser output power. The exhaust air should be no more than about 10°C above ambient for the 30 watt lasers, 15°C above ambient for the 40 watt lasers and 20°C above ambient for the 50 watt lasers. If the exhaust air temperature is significantly higher than these average numbers, it is an indication of inadequate cooling air flow.

5.0 UL OEM Laser Installation and Operation

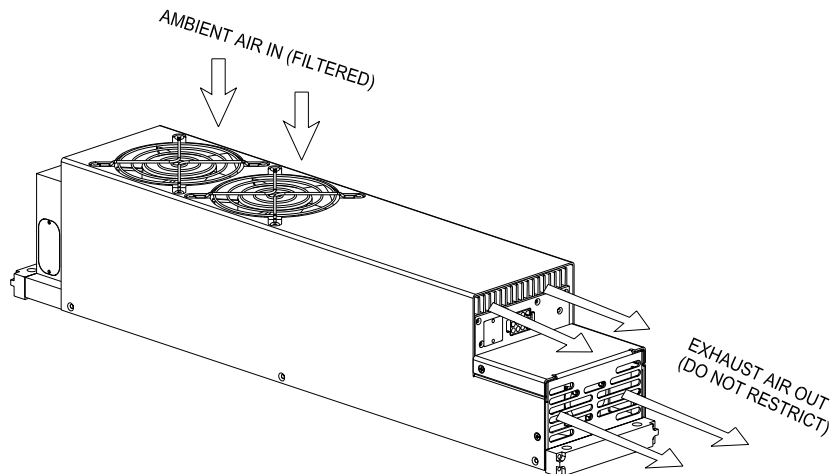

Figure 12 – Detail of air flow through the laser

5.9 Proper Airflow (continued)

Finally, ambient air should be filtered before entering the laser to prevent a buildup of dust and debris on the cooling fins which can reduce cooling efficiency, however, care should be taken when selecting a filter media to ensure that the filter does not restrict air flow. For relatively clean environments, a low restriction filter media (45 pores per inch for example) might be adequate, but for dirtier environments, a heavier filter media might be required and also a booster fan can be employed on the exhaust end to help pull air through the laser.

5.10 Ambient Temperature

Air-cooled lasers by nature are sensitive to ambient temperatures. Hotter ambient temperatures will reduce power output and cooler ambient temperatures will increase power output. An ambient temperature range of 50-95°F [10-35°C] should be observed to guarantee proper laser operation. At temperatures below 50°F [10°C], operation may be intermittent and there is a potential for damage to the power supply and optics. At temperatures above 95°F [35°C], ULS lasers are not guaranteed to provide the rated power output. Lasers can safely be operated at ambient temperatures above 95°F [35°C], however, power output will diminish as ambient temperature rises and longevity can be significantly reduced.

5.11 Laser Beam Output

There are four possible laser beam output configurations available on ULS lasers:

1. Straight beam path.
2. Straight beam path with integrated laser pointer.
3. Right angle beam path.
4. Right angle beam path with integrated laser pointer.

The beam exits the laser as detailed in Figure 13 depending on the configuration selected. If the optional laser pointer is installed, the laser beam and pointer will exit from the aperture with a 0.060" [1.5 mm] displacement from center as seen in Figure 13. This is due to the beam combining optic, which causes a shift in beam position.

An optional mounting plate is available for mounting optics directly to the laser in the straight beam path configuration only. This plate replaces the standard cover plate from which the beam exits the laser. The optional plate is thicker and can be drilled and tapped to mount optics and optics assemblies. Figure 14 provides detailed dimensions for the optional plate. No more than 5 lbs. [2.3 kg] should be cantilevered from this plate.

When integrating a laser with external optics or a beam delivery system, care should be taken to seal the beam path in order to prevent contamination of the laser's optics. Laser optics are exposed to the environment through the beam exit aperture on the laser. Failure to protect laser optics from dust, fumes, and debris will cause premature failure of the laser and can void the warranty. An optional beam window is available from ULS, which mounts over the beam exit aperture of the laser to help protect the laser from contamination.

5.0 UL OEM Laser Installation and Operation

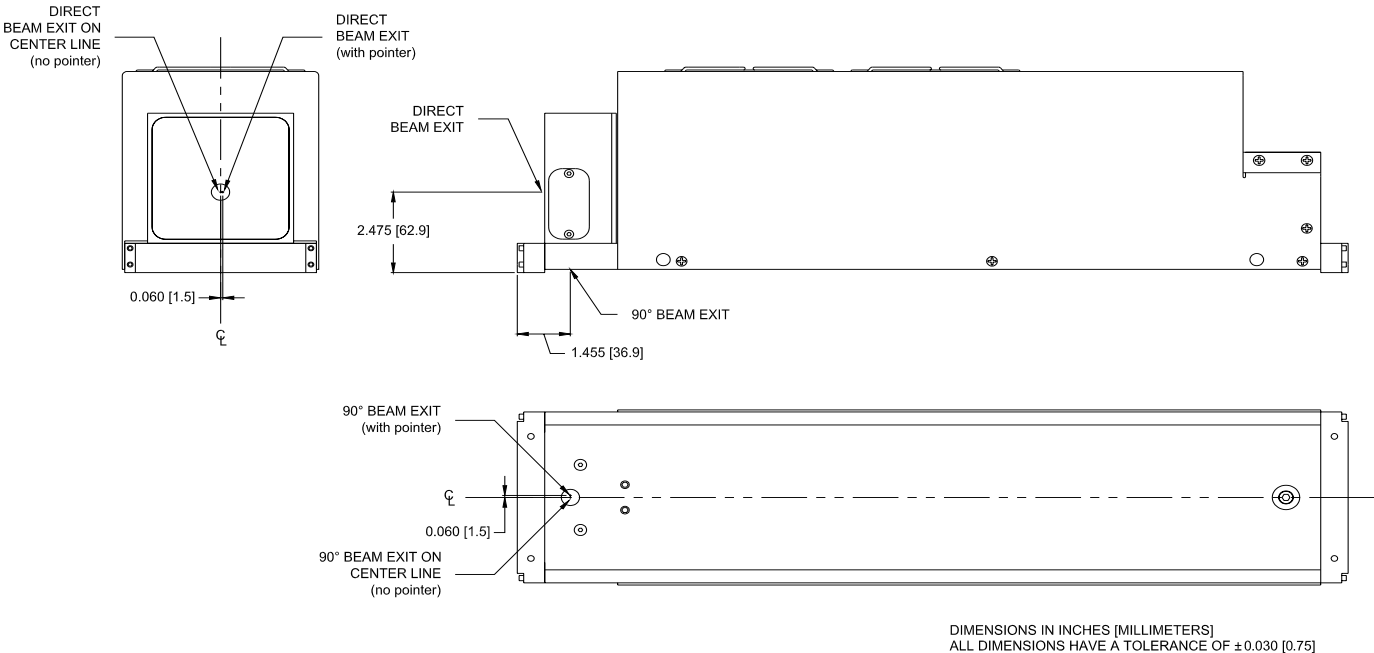

Figure 13 – Detail of Beam Output with and without pointer

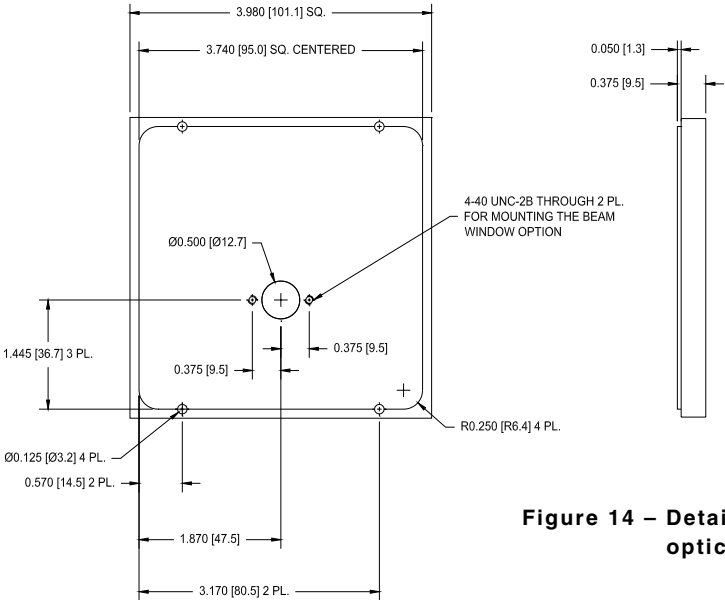

Figure 14 – Detail of optional mounting plate for optics assemblies

5.0 UL OEM Laser Installation and Operation

5.12 Laser Diode Specifications (Optional Accessory)

An optional visible laser diode is available on all models and is factory aligned to the CO₂ beam. The laser diode has the following specifications:

Wavelength: 670 nm
Power Output: 5 mW Max
Class: 3a

A signal must be provided to pin 11 of the power and signal connector to turn the diode off and on. The electrical characteristics of the signal are as follows:

Nominal Voltage: 5 Volt (7 volts max)
Current: 7 mA Min
Logic high: 2.70 Volts Min
Logic Low: 1.725 Volts Max

Warning: Always use protective eyewear when working with exposed laser beams.

Laser diode beams are aligned with the main laser beam at the factory. However, occasionally it may be necessary to realign the diode to the main beam. A small access panel on the side of the front optics box on the laser can be removed to provide access to the three alignment screws surrounding the diode. A piece of masking tape or other suitable material can be placed at a desired distance from the output aperture of the laser and a small mark can be made on it by modulating the laser in a short burst. Then the pointer can be turned on and adjusted until it aligns with the center of the mark made by the main beam. After alignment, a drop of blue Loctite can be applied to the heads of the adjusting screws to help maintain alignment.

6.0 ULC OEM Combo Laser Installation and Operation

6.1 Laser Mounting

Twelve threaded holes are provided on the underside of the Combo laser housing for mounting the laser as shown in Figure 15. The Combo laser can be mounted in any orientation including vertical. Dimensions for the mounting-hole pattern are provided. The laser should be mounted using a three-point arrangement to avoid

warping or bowing the assembly. If the laser is mounted on a flat surface, it should be flat to within 0.025 inches [0.65 mm].

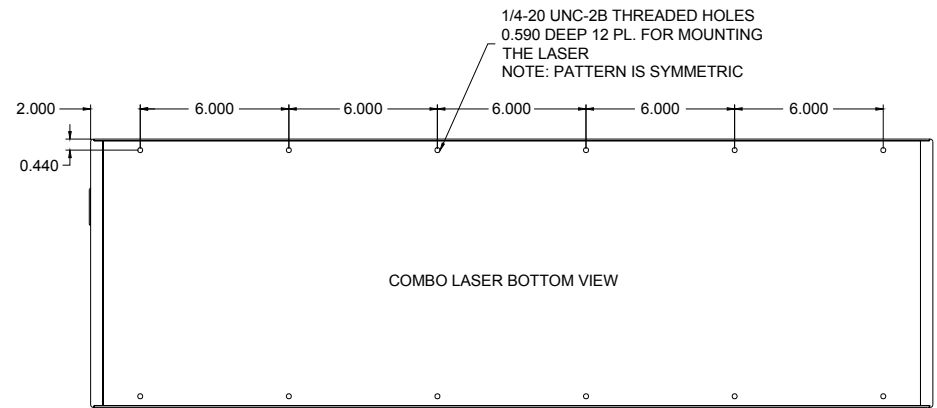
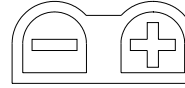

Figure 15 - Detail of mounting holes

6.0 ULC OEM Combo Laser Installation and Operation

6.2 Electrical Connections

All electrical connections for the laser are made through two electrical connectors, a power connector and a signal connector, positioned in the lower left corner of the back of the combo laser package. The power connector requires 8 AWG [3.75 mm²] wire and 22 AWG [0.30 mm²] wire is recommended for the signal connector. Figure 16 below details the connectors and electrical characteristics of each of the pins in the connectors. Figure 17 details the circuits inside the laser attached to the pins.



POWER CONNECTOR MATING HARDWARE
HOUSING AND PINS (COMES AS A SET): ANDERSON 6331G3
PINS HAVE SOLDER CUPS FOR 8 AWG [3.75 mm²] WIRE.
POLARITY IS MARKED ON THE CONNECTOR.
CONNECTORS CAN BE PURCHASED DIRECTLY FROM ANDERSON POWER PRODUCTS.

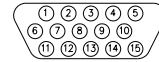

SIGNAL CONNECTOR MATING HARDWARE
HOUSING: STANDARD HIGH DENSITY 15 PIN D-SUB CONNECTOR
22 AWG [0.30 mm²] WIRE RECOMMENDED

Figure 16 – Pin diagram for the laser connectors

Pin Number	Input Name	Laser Input/Output	Wire Size	Description
+	+48V	Power input	8 AWG [3.75 mm ²]	Power +48 volt. Do not swap polarity.
-	Ground	Power input	8 AWG [3.75 mm ²]	Power ground. Do not swap polarity.
Signal Connector				
Pin Number	Input Name	Laser Input/Output	Wire Size	Description
1	Laser A Modulation	Optically isolated input	22 AWG [0.30 mm ²]	Laser A modulation signal is connected between pins 1 and 6. Alternately, Pins 1 and 11 can be tied together and pins 6 and 7 can be tied together and a single source signal used.
2	Laser Diode	Optically isolated input	22 AWG [0.30 mm ²]	+5V signal between pins 2 and 8 will turn on red laser pointer (if
3	Laser A Operational	Optically isolated output	22 AWG [0.30 mm ²]	Optional indicator requires an external +5V source and 470 ohm current-limiting resistor between pins 3 and 8. The optoisolator will activate if the laser has power and the temperature is within limits. The optoisolator will remain open if the laser does not have power, is not connected, or the temperature is out of range.
5	+12V	12 volt interlock source (only use for interlock)	22 AWG [0.30 mm ²]	Connect safety switches between pins 5 and 10 to enable laser. Do not use this pin as a power source for
6	Laser A Modulation Return	Optoisolator return signal	22 AWG [0.30 mm ²]	Optically isolated return signal for "Laser A Modulation" (pin 1).
7	Laser B Modulation Return	Optoisolator return signal	22 AWG [0.30 mm ²]	Optically isolated return signal for "Laser B Modulation" (pin 11).
8	Laser Operational and Laser Diode Return	Optically isolated input	22 AWG [0.30 mm ²]	Optically isolated return signal for "Laser A Operational" (pin 3), "Laser B Operational" (pin 13) and "Laser Diode" (pin 2).
10	Interlock Sense	Input	22 AWG [0.30 mm ²]	+12 volt source applied to this pin enables RF power generation to laser. Intended to be used with safety switches. Do not modulate laser with this signal. See pin 5 for connection info.
11	Laser B Modulation	Optically isolated input	22 AWG [0.30 mm ²]	Laser B modulation signal is connected between pins 11 and 7. Alternately, Pins 1 and 11 can be tied together and pins 6 and 7 can be tied together and a single source signal used.
13	Laser B Operational	Optically isolated output	22 AWG [0.30 mm ²]	Optional indicator requires an external +5V source and 470 ohm current-limiting resistor between pins 13 and 8. The optoisolator will activate if the laser has power and the temperature is within limits. The optoisolator will remain open if the laser does not have power, is not connected, or the temperature is out of range.
4,9,12, 14 & 15	Reserved	Do not use		Reserved for future use.

6.0 ULC OEM Combo Laser Installation and Operation

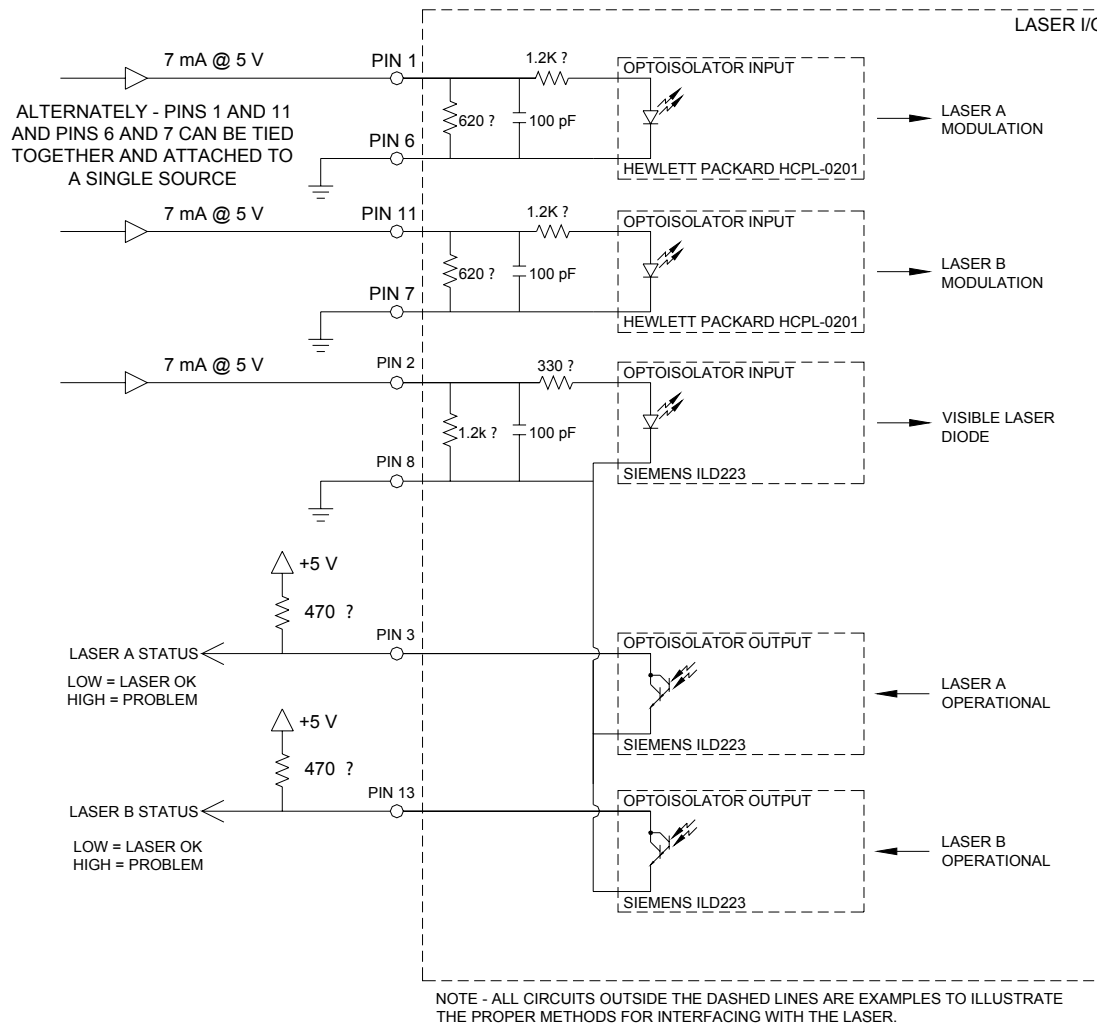

Figure 17a – Laser interconnect schematic Part A

6.0 ULC OEM Combo Laser Installation and Operation

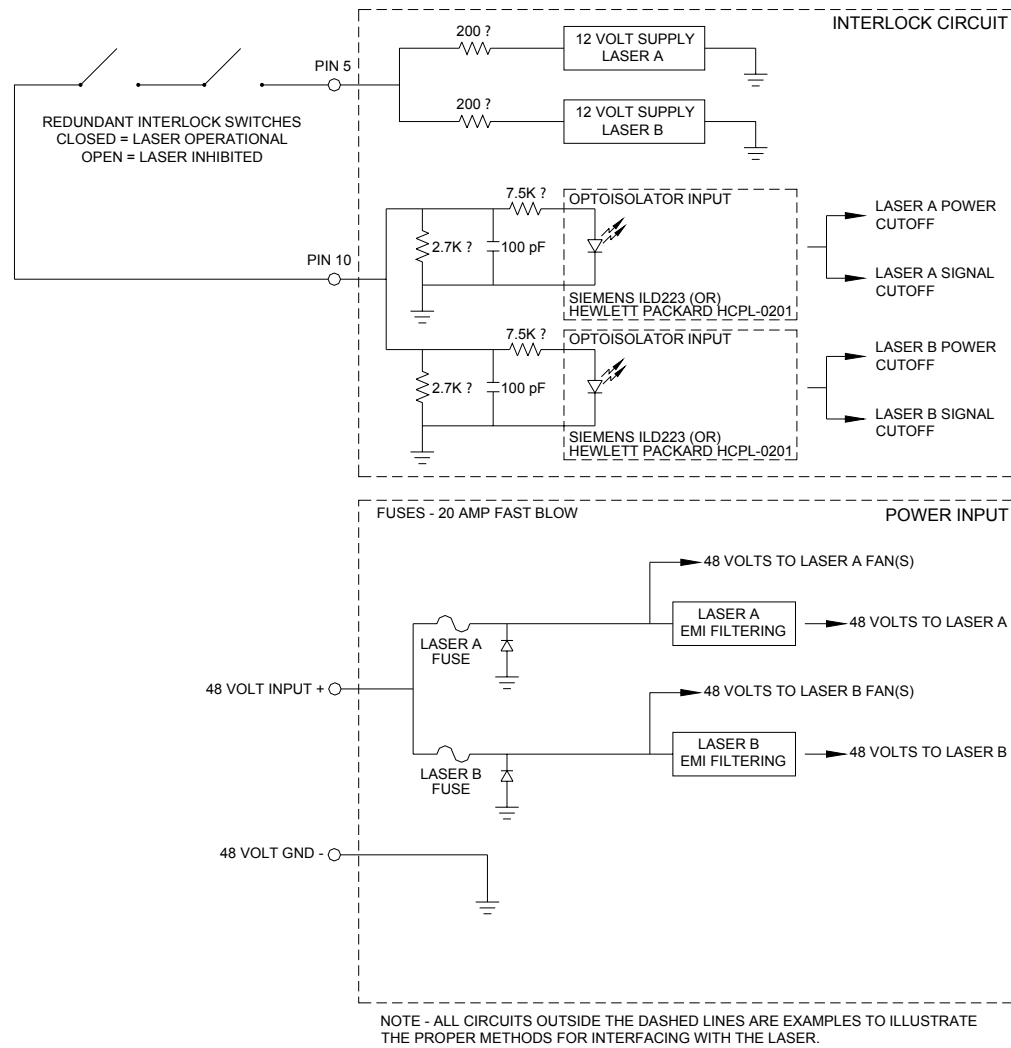

Figure 17b – Laser interconnect schematic Part B

6.0 ULC OEM Combo Laser Installation and Operation

6.3 Power Requirements

A good quality 48 volt DC power supply should be used to power the laser. Nominal output should not exceed 48 volts and regulation should be within 0.5% under 100% load. The power supply should have good transient response characteristics to handle the fluctuating current requirements caused by modulation of the laser. The high current requirements of the combo lasers require the use of heavy gauge wire. Power is supplied to the laser through an Anderson Power Products connector. Each connector includes two pins, one for positive and one for ground, with solder cups designed to accept the recommended 8 gauge wire. Careful attention should be paid to power entry filtering when designing to meet Class A conducted EMI regulations. In order to meet Class A emitted EMI regulations, it is important that the 48 volt power wires be no more than 3 feet (1 meter) in length and that the 48 volt power supply and laser chassis be attached to a common earth ground through very low induction connections.

6.4 Interlock Circuit

An interlock circuit is incorporated into the laser, which can be combined with external switches to satisfy safety requirements when designing Class 1 laser equipment. At least two redundant switches must be used for each panel providing access to a Class 1 enclosure. Please refer to the appropriate safety regulations for more information on Class 1 laser equipment design.

The interlock circuit is self-sourced using a 12 volt output supplied by the laser on pin 5 of the signal connector. The interlock is shunted by connecting pin 5 to pin 10 allowing the laser to operate. Any break in this connection will cause the laser to stop operating. Switches can be placed in series with these pins to create a safety interlock circuit.

6.5 Laser Modulation

A TTL compatible signal must be provided to pins 1 and 11 of the signal connector to drive the laser. Output power can be controlled from 0 to 100% (CW Mode) by pulse width modulation of the input signal. Each tube in the combo laser package can be driven independently by providing separate control signals to the two modulation signal pins or the tubes can be driven as a single unit by connecting pins 1 and 11 together and providing one common signal. If the tubes are driven independently, each will provide a beam with half the rated power of the combo laser. The electrical requirements

for the modulation signal are as follows:

Nominal Voltage: 5 Volt (7 volts max)
Current (minimum): 7 mA (each laser) or 14 mA total
Logic High: 2.70 Volts Min
Logic Low: 1.725 Volts Max

As with all CO₂ lasers, delays are inherent in the response of the laser beam output to the input signal. A typical laser will have response characteristics similar to those detailed in the oscilloscope traces in figures 18 and 19 below. These figures show a TTL signal and corresponding laser power output.

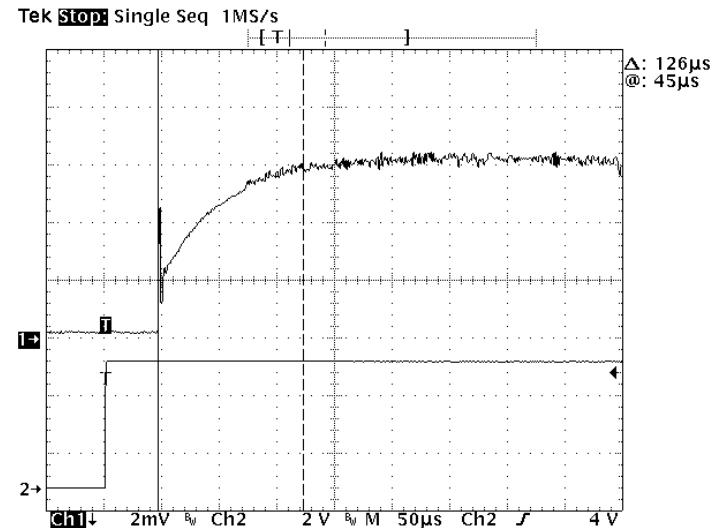

Figure 18 – Oscilloscope trace of typical rise time for a laser

6.0 ULC OEM Combo Laser Installation and Operation

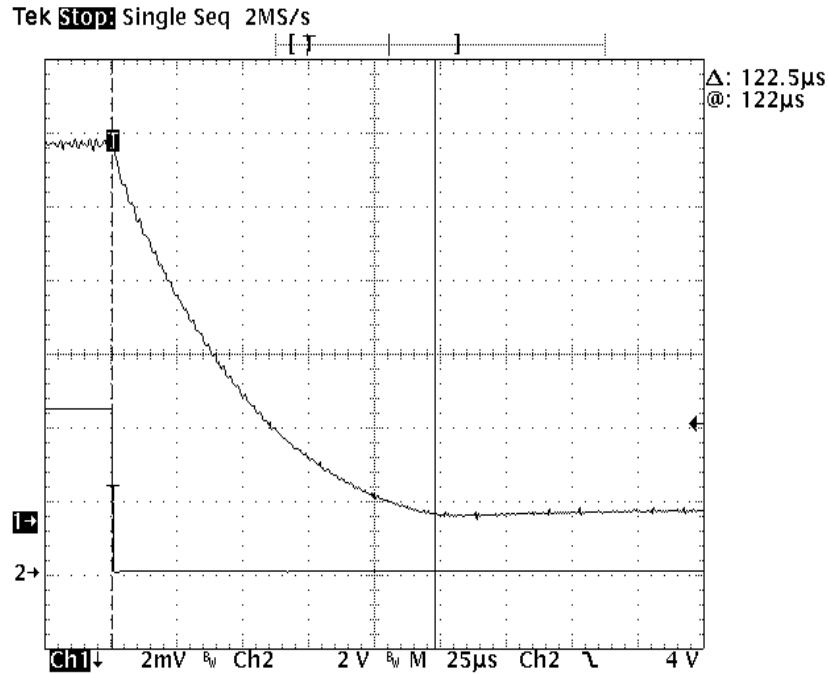

Figure 19 – Oscilloscope trace of typical fall time for a laser

6.6 Laser Tickle

It is a common practice with CO₂ lasers to provide some means of stimulating the mixture when the laser is off in order to improve its response. ULS lasers have a built-in, low duty cycle, secondary modulation signal called a tickle signal to accomplish this effect. This signal is pre-tuned at the factory for optimal performance of the laser and normally does not require adjustment. However, as a laser ages, the pulse width and/or frequency of this signal may need to be increased. This should only be done with authorization of the ULS service department. If the tickle signal needs adjusting, it can be changed using the dipswitches according to figure 20 below. If the tickle must be modified, it will be necessary to remove the main sheetmetal cover to gain access to the two tubes and the dipswitch cover near the internal connector on each tube (see figure 1 for the location of the dipswitch cover on each tube in the combo laser).

Warning: An improperly set tickle signal can cause the laser to produce a continuous beam.

1	2	3	4	5	6	7	8
TICKLE FREQUENCY			TICKLE WIDTH			RESERVED	RESERVED
000	5.8 KHz		000	0.8 µS		"Reserved" must be in the ON position. Damage to the laser will result if turned off.	"Reserved" must be in the ON position. Damage to the laser will result if turned off.
001	5.1 KHz		001	1.5 µS			
010	4.5 KHz		010	2.7 µS			
011	4.1 KHz		011	3.3 µS			
100	3.5 KHz		100	4.1 µS			
101	3.2 KHz		101	4.9 µS			
110	3.0 KHz		110	5.6 µS			
111	2.8 KHz		111	6.0 µS			

Warning: An improperly set tickle signal can cause the laser to produce a continuous beam.
 0= switch OFF 1=switch ON

Figure 20 – Detail of dipswitch showing tickle configuration

6.7 Laser Operational Signal

A separate "laser operational" signal is provided for each tube in the combo laser, one on pin 3 and one on pin 13 of the signal connector. To read the signals, an external +5V source must be provided through a 470 ohm current-limiting resistor to pin 3 and pin 13, and the +5V source's ground connected to pin 8 (the optically-isolated "return" pin). The optoisolator will activate, thus shunting a tube's status pin to ground if a tube has power and the temperature is within limits. The optoisolator will remain open, thus leaving a tube's status pin high if a tube does not have power, is not connected, or the temperature is out of range.

Note: For diagnostic purposes, the condition of the laser operational signal can be checked with a multi-meter without the use of a power source and pull-up resistor. Measure the resistance between pins 3 and 8 for laser A or pins 13 and 8 for laser B using the resistance function of the multi-meter. Make sure that the black (ground) lead is used on pin 8. An open circuit will measure infinite resistance and a closed circuit will measure between 100 and 500 ohms. Open circuit means the laser does not have power, is not connected, or the temperature is out of range.

6.0 ULC OEM Combo Laser Installation and Operation

6.8 Proper Airflow

Careful attention should be paid to proper airflow through the laser (see figure 21) when integrating it into equipment. Any restriction of airflow will result in reduced power output and can cause permanent power loss or failure over extended periods of time. Ambient air should be directed to the laser's intake fan, and exhaust air from the laser should be directed out of equipment with as little restriction as possible. If the laser is placed in an enclosure, it may be necessary to provide additional fans to draw exhaust air out of the enclosure in order to prevent a rise in temperature inside the enclosure, which can affect laser output power. The exhaust air should be no more than about 10°C above ambient for the 60-watt lasers, 15°C above ambient for the 80-watt lasers and 20°C above ambient for the 100-watt lasers. If the exhaust air temperature is significantly higher than these average numbers, it is an indication of inadequate cooling air flow.

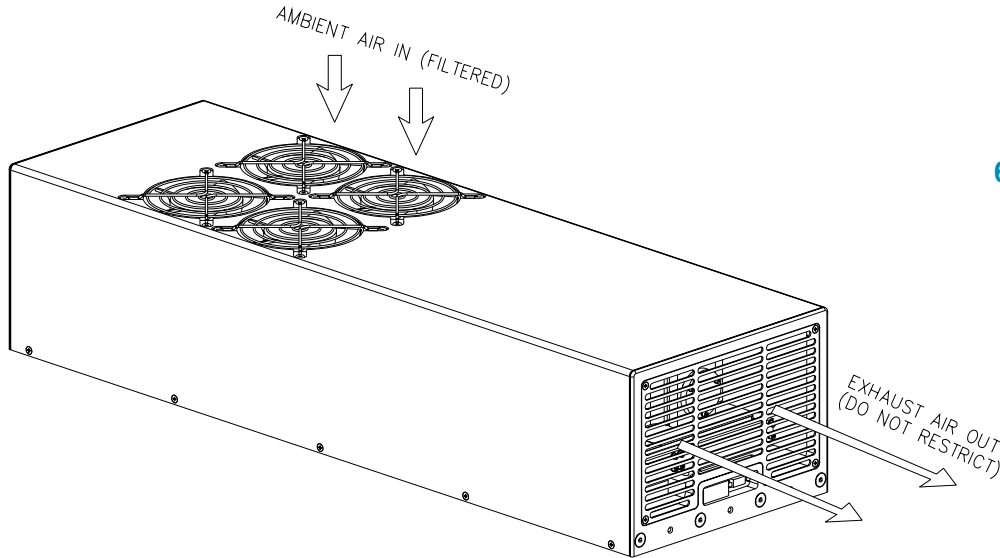

Figure 21 – Detail of air flow through the laser

Finally, ambient air should be filtered before entering the laser to prevent a buildup of dust and debris on the cooling fins which can reduce cooling efficiency, however, care should be taken when selecting a filter media to ensure that the filter does not restrict air flow. For relatively clean environments, a low restriction filter media (45 pores per inch for example) might be adequate, but for dirtier environments, a heavier filter media

might be required and also a booster fan can be employed on the exhaust end to help pull air through the laser.

6.9 Ambient Temperature

Air-cooled lasers by nature are sensitive to ambient temperatures. Hotter ambient temperatures will reduce power output and cooler ambient temperatures will increase power output. An ambient temperature range of 50-95°F [10-35°C] should be observed to guarantee proper laser operation. At temperatures below 50°F [10°C], operation may be intermittent and there is a potential for damage to the power supply and optics. At temperatures above 95°F [35°C], ULS lasers are not guaranteed to provide the rated power output. Lasers can safely be operated at ambient temperatures above 95°F [35°C], however, power output will diminish as ambient temperature rises and longevity can be significantly reduced.

6.10 Laser Diode Specifications (Optional Accessory)

An optional visible laser diode is available on all models and is factory aligned to the CO₂ beam. The laser diode has the following specifications:

Wavelength: 670 nm
Power Output: 5 mW Max
Class: 3a

A signal must be provided to pin 2 of the signal connector to turn the diode off and on. The electrical characteristics of the signal are as follows:

Nominal Voltage: 5 Volt (7 volts max)
Current (minimum): 7 mA Min
Logic High: 2.70 Volts Min
Logic Low: 1.725 Volts Max

7.0 Troubleshooting Tips

7.0 Troubleshooting Tips

If the laser is not producing a beam when installed in a system, the following troubleshooting steps can be performed. Please note the warning before proceeding.

Warning: These steps will bypass the interlock circuit and cause the laser to produce a continuous full power beam. Proper eye-wear and safety precautions must be taken.

1. Verify that 48 volts are present at the laser power connector by measuring voltage across pins 1 and 7 for all UL series lasers or the positive and negative pins at the power connector for all ULC series lasers. If 48 volts are not present, correct the situation.
2. If 48 volts are present, then bypass the interlock by connecting a jumper between pins 5 and 8 on the UL series lasers or pins 5 and 10 at the signal connector of the ULC series lasers.

Warning: This next step will cause the laser to produce a continuous full power beam. Proper eyewear and safety precautions must be taken. Make sure that a proper beam absorbing material is placed in the beam path.

3. With the interlock bypassed per step 2, turn the laser on in CW mode by applying 5 volts across pins 6 and 9 (positive to pin 6) on all UL series lasers or pins 1,11 and 6,7 (positive to pins 1 and 11 and negative to pins 6 and 7) on all ULC series lasers.

7.1 Shipping Lasers Back for Repair or Refill

If a laser requires repair or a refill, a return authorization can be obtained through the ULS Service Department. When shipping a laser back to ULS, it is important to use the original shipping materials in order to avoid shipping damage. If you have lost or discarded the original shipping material and need new shipping materials, the ULS Service Department will be happy to provide them.

UNIVERSAL
LASER SYSTEMS INC.

Innovation • Experience • Commitment

www.co2laser.com

16008 North 81st Street • Scottsdale, AZ 85260 • tel: 1.800.859.7033 or 480.483.1214 • fax:480.483.5620 • email: ghigman@ulsinc.com

Pin Number	Input Name	Laser Input/Output	Wire Size	Description
+	+48V	Power input	8 AWG [3.75 mm ²]	Power +48 volt. Do not swap polarity
-	Ground	Power input	8 AWG [3.75 mm ²]	Power Ground. Do not swap polarity
Signal Connector				
Pin Number	Input Name	Laser Input/Output	Laser Input/Output	Description
1	Laser A Modulation	Optically isolated Input	22 AWG [.30 mm ²]	Laser A modulation signal is connected between pins 1 and 6. Alternately, Pins 1 and 11 can be tied together and pins 6 and 7 can be tied together and a single source signal used.
2	Laser Diode	Optically isolated input	22 AWG [.30 mm ²]	+5 V signal between pins 2 and 8 will turn on red laser pointer (if equipped).
3	Laser A Operational	Optically isolated output	22 AWG [.30 mm ²]	Optional indicator requires an external +5V source and 470 ohm current-limiting resistor between pins 3 and 8. The optoisolator will activate if the laser has power and the temperature is within limits. The optoisolator will remain open if the laser does not have power, is not connected, or the temperature is out of range.
5	+12V	12 volt interlock source (only use for interlock)	22 AWG [.30 mm ²]	Connect safety switches between pins 5 and 10 to enable laser. Do not use this pin as a power source for other purposes.
6	Laser A Modulation Return	Optoisolator return signal	22 AWG [.30 mm ²]	Optically isolated return signal for "Laser A Modulation" (pin 1).
7	Laser B Modulation Return	Optoisolator return signal	22 AWG [.30 mm ²]	Optically isolated return signal for "Laser B Modulation" (pin 11).
8	Laser Operational and Laser Diode Return	Optically isolated input	22 AWG [.30 mm ²]	Optically isolated return signal for Laser A Operational (pin 3), Laser B Operational (pin 13) and Laser Diode (pin 2).
10	Interlock Sense	Input	22 AWG [.30 mm ²]	+12 volt source applied to this pin enables RF power generation to laser. Intended to be used with safety switches. Do not modulate laser with this signal. See pin 5 for connection info.
11	Laser B Modulation	Optically isolated output	22 AWG [.30 mm ²]	Laser B modulation signal is connected between pins 11 and 7. Alternately, Pins 1 and 11 can be tied together and pins 6 and 7 can be tied together and a single source signal used.
13	Laser B Operational	Optically isolated output	22 AWG [.30 mm ²]	Optional indicator requires an external +5V source and 470 ohm current-limiting resistor between pins 13 and 8. The optoisolator will activate if the laser has power and the temperature is within limits. The optoisolator will remain open if the laser does not have power, is not connected, or the temperature is out of range.
4,9,12, 14 & 15	Reserved	Do not use		Reserved for future use.

Pin Number	Input Name	Laser Input/Output	Wire Size	Description
+	+48V	Power input	8 AWG [3.75 mm ²]	Power +48 volt. Do not swap polarity
-	Ground	Power input	8 AWG [3.75 mm ²]	Power Ground. Do not swap polarity
Signal Connector				
Pin Number	Input Name	Laser Input/Output	Laser Input/Output	Description
1	Laser A Modulation	Optically isolated Input	22 AWG [.30 mm ²]	Laser A modulation signal is connected between pins 1 and 6. Alternately, Pins 1 and 11 can be tied together and pins 6 and 7 can be tied together and a single source signal used.
2	Laser Diode	Optically isolated input	22 AWG [.30 mm ²]	+5 V signal between pins 2 and 8 will turn on red laser pointer (if equipped).
3	Laser A Operational	Optically isolated output	22 AWG [.30 mm ²]	Optional indicator requires an external +5V source and 470 ohm current-limiting resistor between pins 3 and 8. The optoisolator will activate if the laser has power and the temperature is within limits. The optoisolator will remain open if the laser does not have power, is not connected, or the temperature is out of range.
			22 AWG [.30 mm ²]	
5	+12V	12 volt interlock source (only use for interlock)		Connect safety switches between pins 5 and 10 to enable laser. Do not use this pin as a power source for other purposes.
6	Laser A Modulation Return	Optoisolator return signal	22 AWG [.30 mm ²]	Optically isolated return signal for "Laser A Modulation" (pin 1).
7	Laser B Modulation Return	Optoisolator return signal		Optically isolated return signal for "Laser B Modulation" (pin 11).
8	Laser Operational and Laser Diode Return	Optically isolated input	22 AWG [.30 mm ²]	Optically isolated return signal for Laser A Operational (pin 3), Laser B Operational (pin 13) and Laser Diode (pin 2).
			22 AWG [.30 mm ²]	
10	Interlock Sense	Input	22 AWG [.30 mm ²]	+12 volt source applied to this pin enables RF power generation to laser. Intended to be used with safety switches. Do not modulate laser with this signal. See pin 5 for connection info.
11	Laser B Modulation	Optically isolated output	22 AWG [.30 mm ²]	Laser B modulation signal is connected between pins 11 and 7. Alternately, Pins 1 and 11 can be tied together and pins 6 and 7 can be tied together and a single source signal used.
13	Laser B Operational	Optically isolated output	22 AWG [.30 mm ²]	Optional indicator requires an external +5V source and 470 ohm current-limiting resistor between pins 13 and 8. The optoisolator will activate if the laser has power and the temperature is within limits. The optoisolator will remain open if the laser does not have power, is not connected, or the temperature is out of range.
			22 AWG [.30 mm ²]	
4,9,12,	Reserved	Do not use		Reserved for future use.
14 & 15				