

UNIVERSAL[®] **L A S E R S Y S T E M S**

OEM CO₂ LASER **Integration Manual** **OEM Basic Water**

Universal Laser Systems, Inc.

16008 North 81st Street
Scottsdale, AZ 85260
Phone: 480-483-1214
Fax: 480-483-5620

October 2006

Notice

This publication and its contents are proprietary to Universal Laser Systems, Inc. (ULS), and are intended solely for the contractual use of ULS, Inc. customers.

While reasonable efforts have been made to assure the accuracy of this manual, ULS shall not be liable for errors contained herein or for incidental or consequential damage in connection with the furnishing, performance, or use of this material.

ULS reserves the right to revise this manual and make changes from time to time without obligation by ULS to notify any person of such revision or changes.

ULS does not assume any liability arising out of the application or use of any products, circuits, or software described herein. Neither does it convey a license under its patent rights nor the patent rights of others.

This publication and its contents may not be reproduced, copied, transmitted, or distributed in any form, or by any means, radio, electronic, mechanical, photocopying, scanning, facsimile, or otherwise, or for any other purpose, without the prior written permission of ULS.

Intended use of this product must be followed within the guidelines of this manual. In no event will ULS be liable for any damages caused, in whole or in part, by customer, or for any economic loss, physical injury, lost revenue, lost profits, lost savings or other indirect, incidental, special or consequential damages incurred by any person, even if ULS has been advised of the possibility of such damages or claims.

WARNING: Universal Laser Systems products are not designed, tested, intended or authorized for use in any medical applications, surgical applications, medical device manufacturing, or any similar procedure or process requiring approval, testing, or certification by the United States Food and Drug Administration or other similar governmental entities.

The product described herein is covered under one or more of U.S. Patents 5,661,746; 5,754,575; 5,867,517; 5,881,087; 5,894,493; 5,901,167; 5,982,803; 6,181,719.

**© Universal Laser Systems Inc., 2006
All Rights Reserved**

Contents

Notice.....	2
Contents	3
1.0 Introduction.....	4
2.0 Specifications.....	5
3.0 Safety Issues	8
3.1 Laser Safety	8
3.2 Electrical Safety	8
3.3 Electromagnetic Interference	8
3.4 Contacts for Safety Information.....	9
4.0 A Brief Description of the Laser.....	10
5.0 ULR OEM Laser Installation and Operation.....	11
5.1 Laser Mounting.....	11
5.2 Electrical Connections	11
5.3 Power Requirements	14
5.4 Interlock Circuit.....	14
5.5 Laser Modulation.....	14
5.6 Laser Operational Signals.....	16
6.0 Air Cooling.....	16
6.1 Proper airflow	16
6.2 Ambient temperature	17
7.0 Water Cooling.....	18
7.1 Water Connections.....	18
7.2 Coolant.....	18
7.3 Environmental.....	18
7.4 Chiller Capacity	19
7.5 Draining the Laser.....	19
8.0 Laser Troubleshooting Guide	20
9.0 Shipping Lasers Back for Repair or Refill.....	22
10.0 Recycling	22
APPENDIX A: UL-8 Laser Serial Communications Protocol.....	23

1.0 Introduction

Thank you for choosing a Universal Laser Systems CO₂ laser for your application. ULS is committed to providing the marketplace with low cost CO₂ lasers, which take advantage of our patented technology to provide compact size, ease of integration and high performance. This integration manual will guide you through the process of installing a ULS laser into your equipment and provide you with the information you need to operate the laser. Please read this entire manual and familiarize yourself with its contents. If you need help please feel free to call Universal Laser Systems and we will be happy to provide you with assistance.

2.0 Specifications

Specifications for all UL OEM CO₂ Lasers are summarized below.

Parameter*	Model			
	ULR-25 ULR-30	ULR-40	ULR-50 ULR-60	ULR-75
Rated Power**	25W or 30 W	40 W	50W or 60 W	75W
Wavelength	10.6 μ			
Power Stability	\pm 5% after 15 minutes of CW operation			
M ²	1.4 \pm .2			
Beam Size (Near Field)****	4 \pm 1 mm			
Beam Divergence (Full Angle)	5 \pm 1 mr			
Polarization	Linear (Perpendicular to the laser base plate)			
Pointing Stability	200 μ R			
Optical Pulse Rise or Fall Time	120 \pm 40 μ S			
Optical Delay Time	38 \pm 10 μ S			
Optical Modulation	100% up to 5 KHz			
Modulation Signal Type	TTL Compatible			
Cooling	Air (built in) or Water (built in)			
Weight (Basic Air-Cooled)	18 Lb. [8.1 kg]	21 Lb. [9.5 kg]	24 Lb. [10.9 kg]	29 Lb. [13.1 kg]
Weight (Integrated Air-Cooled)	20 Lb. [9.0 kg]	23 Lb. [10.5 kg]	26 Lb. [11.8 kg]	31 Lb. [14.0 kg]
Weight (Integrated Water-Cooled)	20 Lb. [9.0 kg]	23 Lb. [10.5 kg]	25 Lb. [11.8 kg]	30 Lb. [14.0 kg]
Environmental				
Ambient Temperature***	50-95 °F [10-35 °C]			
Relative Humidity	< 90% (non-condensing)			
Power Requirements				
DC Input Voltage	48.0 VDC			
RMS Current (CW, including fan)	10 A	14 A	18 A	20 A
Inrush Current	70 A, 150 μ S			

* The above specifications are subject to change without notice.

** Output power is guaranteed to exceed this level for the duration of the warranty, regardless of run-time.

*** At temperatures below 50 °F [10 °C] operation may be intermittent and there is a potential for damage to the power supply and optics.

**** Near field is approximately 150mm from output-coupler.

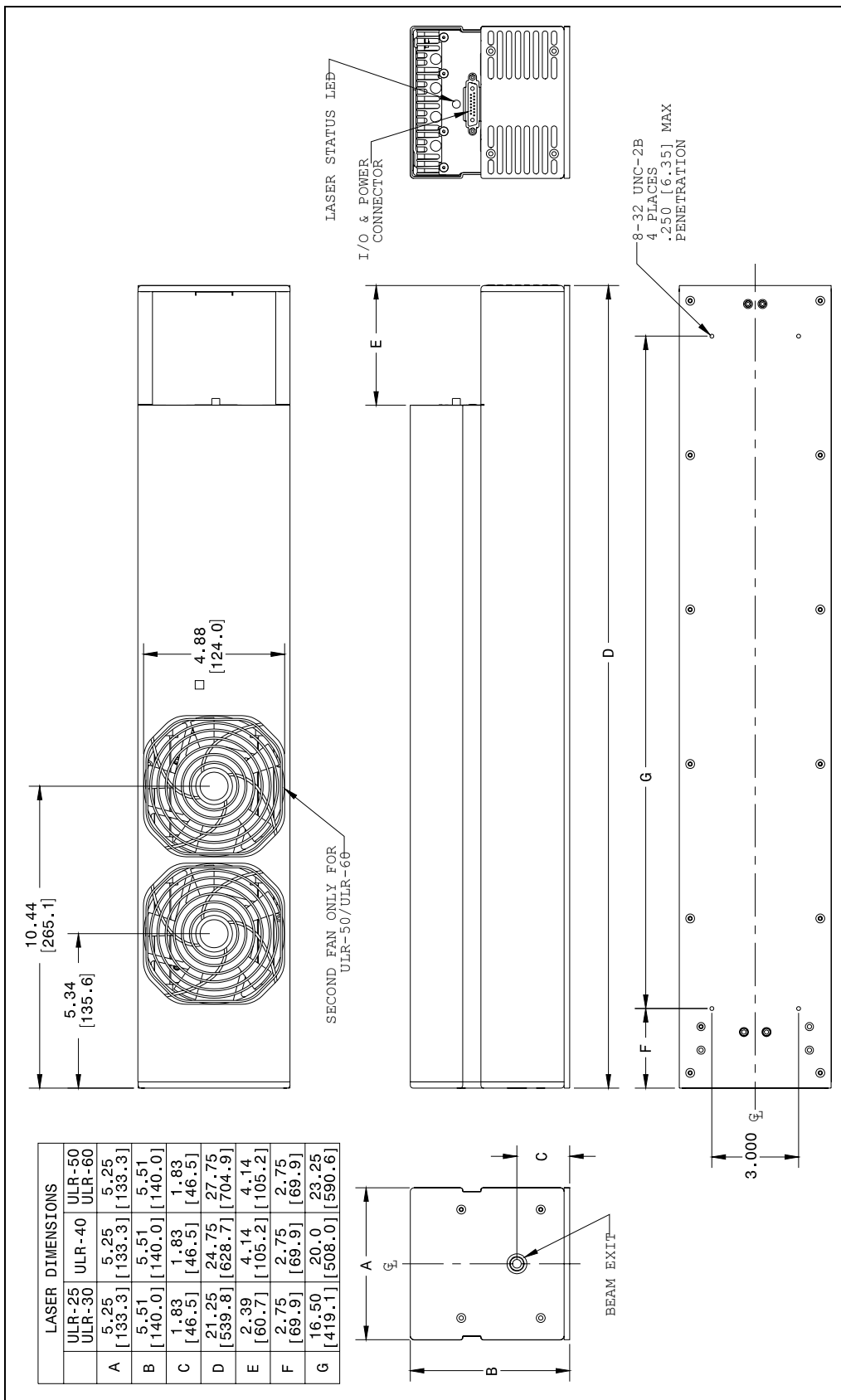

Figure 1 – Dimensional Specifications – Integrated Air Cooled

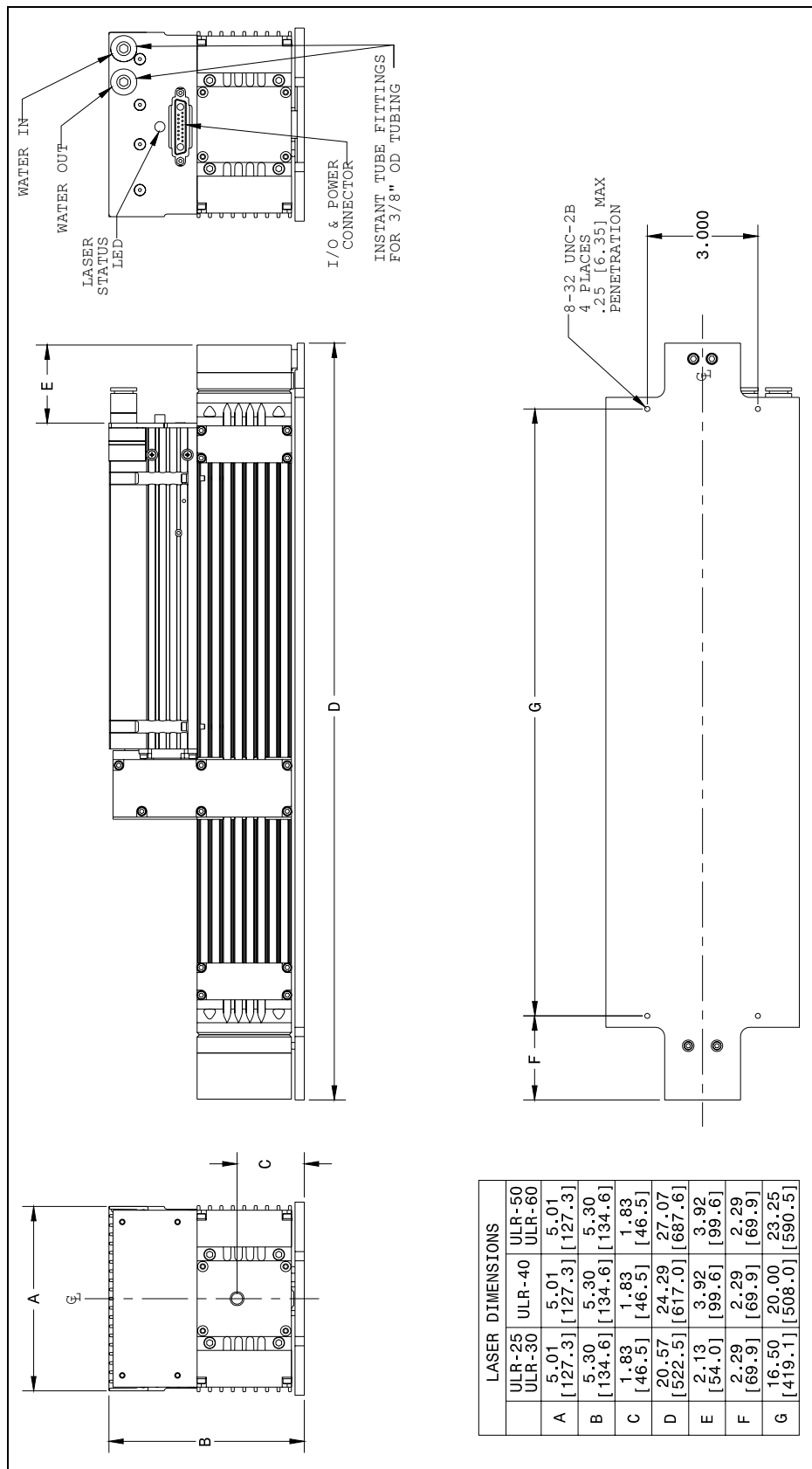

Figure 2 – Dimensional Specifications – Basic Water Cooled

3.0 Safety Issues

3.1 Laser Safety

ULS OEM lasers are sold as components and therefore are not required to conform to U.S. or European safety regulations. It is the responsibility of the buyer to design and certify any equipment incorporating a ULS OEM laser to meet all local safety regulations prior to sale to the public. The texts of these regulations are available from the respective governing bodies of the countries the equipment is to be sold into.

Any personnel working with or around open lasers must be aware of the following:

- **Exposure to the laser beam may cause physical burns and can cause severe eye damage.** Proper eye protection should be used at all times. All eye protection should be appropriate for the radiation wavelength generated by the laser in use.
- **Exposure to the laser beam may cause ignition of volatile or combustible materials.** Do not use lasers in the presence of these types of materials.
- **Never look directly into the laser output port.**
- **Interlock all rooms in which open beams may be present and post appropriate warnings on or near the doors.** Access to these rooms should be limited to properly trained technicians when lasers are in use.
- **Use appropriate protective coverings over all beam paths whenever possible.**
- **Lasers and optical elements should be positioned to keep the beam and reflections below eye level.**

Notice: For more information on EMI standards, refer to local EMI safety regulations.

3.2 Electrical Safety

ULS lasers operate at 48 VDC, which is below the voltage limit that is considered dangerous by most safety standards. However, the lasers draw large amounts of current and the power supplies needed to provide the 48 VDC usually require 90-240 VAC to operate. For these reasons, proper safety precautions should be taken with every portion of the electrical system.

Notice: For more information on EMI standards, refer to local EMI safety regulations.

3.3 Electromagnetic Interference

ULS OEM lasers are sold as components and therefore are not required to conform to all U.S. or European safety regulations regarding EMI. It is the responsibility of the customer to design and certify any equipment incorporating a ULS OEM laser to meet all local safety regulations prior to sale to the public. However, testing by ULS has demonstrated that with a

properly selected power supply and line filtering all ULS OEM lasers will pass the relevant U.S. and European EMI standards for Class A equipment. See Section 5.3 for more information.

Notice: For more information on EMI standards, refer to local EMI safety regulations.

3.4 Contacts for Safety Information

It is the responsibility of the integrator to meet all applicable safety standards required by the authorities of the region that the unit will be operating in. Below is a list of useful contacts for information on safety regulations in the U.S. Canada, and Europe:

United States

Food and Drug Administration - Center for Devices and Radiological Health (CDRH), 1-800-638-2041.

Federal Communications Commission (FCC), (301)362-3000.

Underwriters Laboratories Inc. (UL), Illinois (708)272-8800, New York (516)271-6200, California (408)985-2400.

Laser Safety Institute of America, (407)380-1553.

Occupational Safety and Health Administration, (202)693-2300.

Canada

Canadian Standards Association (CSA), (416) 747-4000.

Europe

European Committee for Electrotechnical Standardization (Cenelec), rue de Stassart 35, B-1050 Brussels

International Organization for Standardization (ISO), 1 rue de Varembé, Case postale 56, CH-1211 Genève 20 Switzerland

4.0 A Brief Description of the Laser

ULR OEM Lasers

All ULS OEM CO₂ gas lasers use a sealed-off, RF excited, slab design and a multi-pass, free space resonator¹. Each laser consists of a plasma tube, with mirrors at each end forming an optical resonator, and an RF power supply assembled together in a chassis which can be configured with an integrated cooling fan or integrated water-cooling. Convenient mounting provisions are provided in the laser-baseplate.

The plasma tube consists of two opposing electrodes in a slab configuration meaning the cross-section of the gap between the electrodes is rectangular instead of square. This allows for a multi-pass resonator in which the laser beam makes several passes within the plasma using the full width of the rectangular electrode gap. The advantage of this is a powerful laser beam from a relatively short tube.

The length of the gap between the electrodes is designed to allow free space operation of the laser. This means that the gap is wide enough to allow the laser beam to form without any substantial waveguide effects caused by reflection of light from the surfaces of the electrodes. This provides for a very good quality beam in the near field as well as far field.

The optical resonator is formed by a system of three mirrors, one in the back and two in the front with one front mirror being partially reflective to allow the beam to exit the tube. These mirrors are tuned to specific angles to generate multiple passes of the laser beam within the plasma formed between the electrodes.

Each electrode is attached to the RF power supply through a matching network that allows the impedance of the tube to be tuned to match the impedance of the supply. The RF power supply operates at approximately 40 MHz. Power control of the laser beam is provided through pulse width modulation of the RF by an external TTL signal provided by the user.

ULC OEM Combo Lasers

The combo line of lasers takes advantage of the linear polarization of the laser beams from two standard ULR lasers to optically combine the beams. The two lasers are mounted together in a rigid housing and optically aligned so that the beams are collinear creating a new laser product with double the power output of our standard single tube lasers. To combine the beams, the polarization vector and the ellipticity of one laser is rotated ninety degrees to that of the other and then both beams are directed through a combining element. This results in a combined beam that is randomly polarized with little to no ellipticity. The combo lasers are available with integrated fans for air cooling or integrated water cooling.

¹ As described in U.S. Patent 5,661,746

5.0 ULR OEM Laser Installation and Operation

5.1 Laser Mounting

There are 8-32 threaded holes used for mounting located in the laser base-plate, as shown in Figure 1. The laser can be mounted in any orientation including vertical. Dimensions for the mounting-hole pattern are given below. The laser should be mounted using a three point arrangement to avoid warping or bowing the assembly. If the laser is mounted on a flat surface it should be flat to within .025 inches [.65 mm].

5.2 Electrical Connections

All electrical and communication connections for the laser are made through one 15 + 2-pin connector located on the back of the laser. The mating connector will accommodate up to 8 AWG [8.35 mm²] wire for power and 22 AWG [0.33 mm²] wire for signals. Figure 2 below details the electrical characteristics of each of the pins in the connector. Figure 3 details the circuits inside the laser attached to the pins.

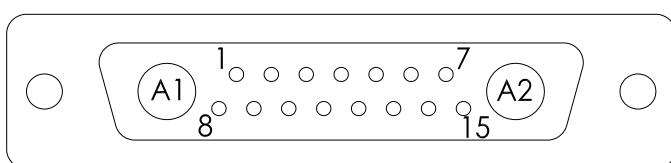

WIRE HARNESS MATING CONNECTOR:
POSITRONIC: CBD17W2F20000
(POWER PINS: FS40080)

Figure 3 – Laser Connector Pin Diagram

Pin Number	Input Name	Laser Input/Output	Wire Size	Description
1	-D	RS485 -	22 AWG [0.33mm ²]	Half- duplex communication port. Use twisted-pair with +D(pin 2).
2	+D	RS485 +	22 AWG [0.33mm ²]	Half- duplex communication port. Use twisted-pair with -D(pin 1).
3	Modulation -	Optically isolated return signal	22 AWG [0.33mm ²]	Optically isolated return signal for "modulation +" (pin 4). See <i>note 1</i>
4	Modulation +	Optically isolated input	22 AWG [0.33mm ²]	Laser modulation signal is connected between pins 3 and 4.
5	Key +	+12 volt source (only use for external key)	22 AWG [0.33mm ²]	Internally switched for use in Class IV mode. Not available in OEM mode. 50mA output. See <i>note 2</i>
6	Key -	Key + Return	22 AWG [0.33mm ²]	Return pin for key.

7	Status 1 Out	TTL Output	22 AWG [0.33mm ²]	HI= Normal Low= Fault See note 3
8	N.C	No internal connection.		
9	Laser Diode Input	Optically isolated input	22 AWG [0.33mm ²]	+5 V signal on pin 2 will turn on the red laser pointer (when available).
10	Laser Diode Return	Optically isolated return signal	22 AWG [0.33mm ²]	Optically isolated return signal for "Laser Diode" (pin 9). See note 1
11	Emission Status Output	Output to external LED (10mA)	22 AWG [0.33mm ²]	Not available in OEM mode.
12	Emission Status Return	Emission Status Return	22 AWG [0.33mm ²]	Power Ground.
13	Interlock -	Interlock return	22 AWG [0.33mm ²]	See description for Pin 14. 50mA output. See note 2
14	Interlock +	12 volt source (only use for interlock)	22 AWG [0.33mm ²]	Connect safety switches between pins 14 and 13 to enable laser. Do not use this pin as a power source for other purposes.
15	Temperature Warning	TTL Output	22 AWG [0.33mm ²]	HI= Normal Low= Fault See note 3
A1	Power Ground	Power input	8 AWG [8.35 mm ²]	Power ground. See note 4.
A2	+48V	Power input	8 AWG [8.35 mm ²]	+48 volt power; do not swap polarity. See note 4.

Notes:

1. Pins 3 & 10 are internally connected. This ground is capacitively coupled to chassis ground and is provided as an isolated ground for the customer and as a return for the customer supplied +5V.
2. 50mA is available for the interlock and key circuits. This current is shared between the two circuits and it is not recommended that external loads be placed inline.
3. 50mA is available on TTL outputs (total).
4. The solder cups for A1 and A2 can be used with up to 8AWG wire. See Section 5.3 *Power Requirements* for recommended power wiring.

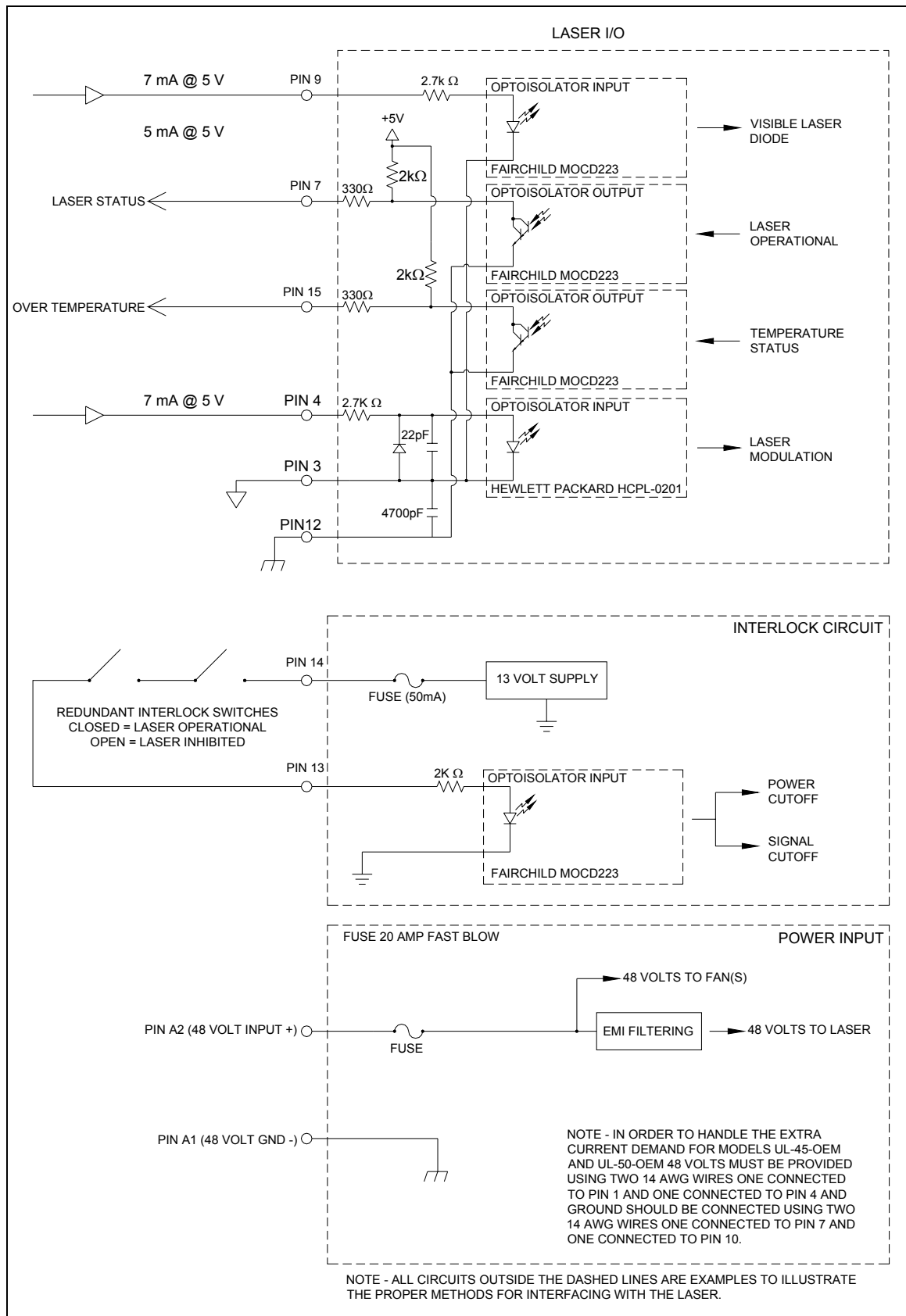

Figure 4 – Laser Interconnect Schematic

5.3 Power Requirements

A good quality 48 volt DC power supply should be used to power the laser. Nominal output should not exceed 48 volts and regulation should be within .5% under 100% load. The power supply should have good transient response characteristics to handle the fluctuating current requirements caused by modulation of the laser. Careful attention should be paid to power entry filtering when designing to meet Class A conducted EMI regulations. In order to meet Class A emitted EMI regulations, it is important that the 48 volt power wires be no more than 3 feet (1 meter) in length and that the 48 volt power supply and laser chassis be attached to a common earth ground through very low induction connections.

The solder cups for the power terminals in the provided connector can accept up to 8AWG wire. Recommended wire gauges are as follows:

<i>MODEL</i>	<i>WIRE SIZE</i>
ULR-25 / ULR-30	14 AWG
ULR-40	14 AWG
ULR-50 / ULR-60	12 AWG
ULR-75	10 AWG

5.4 Interlock Circuit

An interlock circuit is incorporated into the laser, which can be combined with external switches to satisfy safety requirements when designing Class 1 laser equipment. At least two redundant switches must be used for each panel providing access to a Class 1 enclosure. Please refer to the appropriate safety regulations for more information on Class 1 laser equipment design.

The interlock circuit is self-sourced using a 12 volt output supplied by the laser on pin 14. The interlock is shunted by connecting pin 14 to pin 13 allowing the laser to operate. Any break in this connection will cause the laser to stop operating. Switches can be placed in series with these pins to create a safety interlock circuit.

5.5 Laser Modulation

A TTL compatible signal must be provided to pin 4 to drive the laser (with pin 3 being the return). Output power can be controlled from 0 to 100% (CW Mode) by pulse width modulation of the input signal. The electrical requirements for the modulation signal are as follows:

Nominal Voltage	5 Volt (7 volts max)
Current	7 mA Min
Logic high	2.70 Volts Min
Logic Low	1.725 volts Max

As with all CO₂ lasers, delays are inherent in the response of the laser beam output to the input signal. A typical laser will have response characteristics similar to those detailed in the oscilloscope traces in figures 4 and 5 below. These figures show a TTL signal and corresponding laser power output.

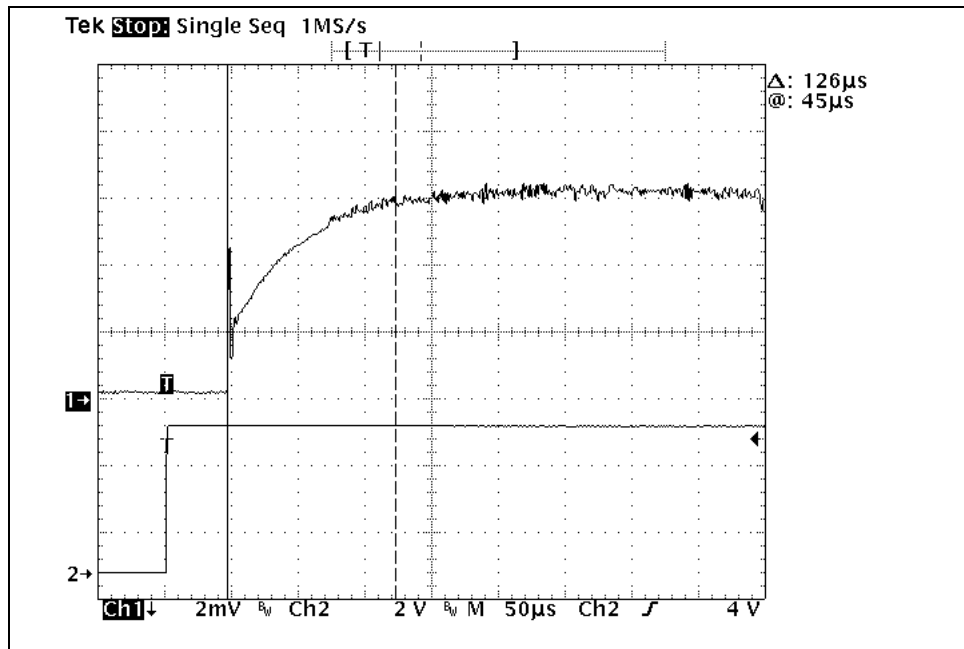

Figure 5 – Oscilloscope trace of typical rise time for a laser

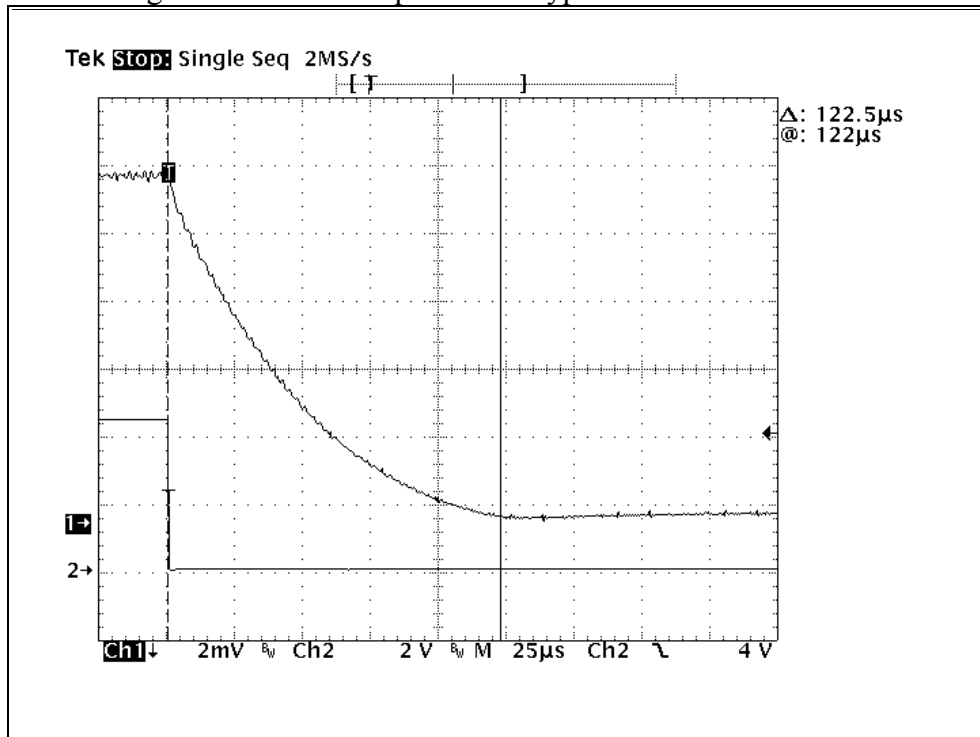

Figure 6 – Oscilloscope trace of typical fall time for a laser

5.6 Laser Operational Signals

A "laser status" signal is provided on pin 7 for diagnostic purposes (pin 12 is the return). This signal will be high for normal operation and low for fault. During a fault, the laser will not operate. Faults include: Interlock circuit open; Keyswitch off (Class IV version); Over-temperature; Under-temperature; Failure in the internal power circuit.

A "temperature warning" signal is provided on pin 15 (pin 12 is the return). When tube temperature approaches over-temperature or approaches under-temperature, this signal will go low and the laser will continue to operate.

This laser is equipped with RS-485 communications for control and diagnostic purposes. Pins 1 and 2 are used for this purpose. Please refer to Appendix A, Communication Protocol.

6.0 Air Cooling

6.1 Proper airflow

Careful attention should be paid to proper airflow through the laser (see figure 6) when integrating it into equipment. Any restriction of airflow will result in reduced power output and can cause permanent power loss or failure over extended periods of time. Ambient air should be directed to the laser's intake fan(s), and exhaust air from the laser should be directed out of equipment with as little restriction as possible. If the laser is placed in an enclosure it may be necessary to provide additional fans to draw exhaust air out of the enclosure to reduce a rise in temperature inside the enclosure, which can affect laser output power. A general guideline to determine adequate airflow is shown in the following table. If exhaust air temperatures are significantly above those listed, that is an indication of inadequate air flow.

LASER MODEL	EXHAUST AIRTEMPERATURE
ULR-25 / ULR-30	<10°C above intake temperature
ULR-40	<15°C above intake temperature
ULR-50 / ULR-60	<20°C above intake temperature
ULR-75	<25°C above intake temperature

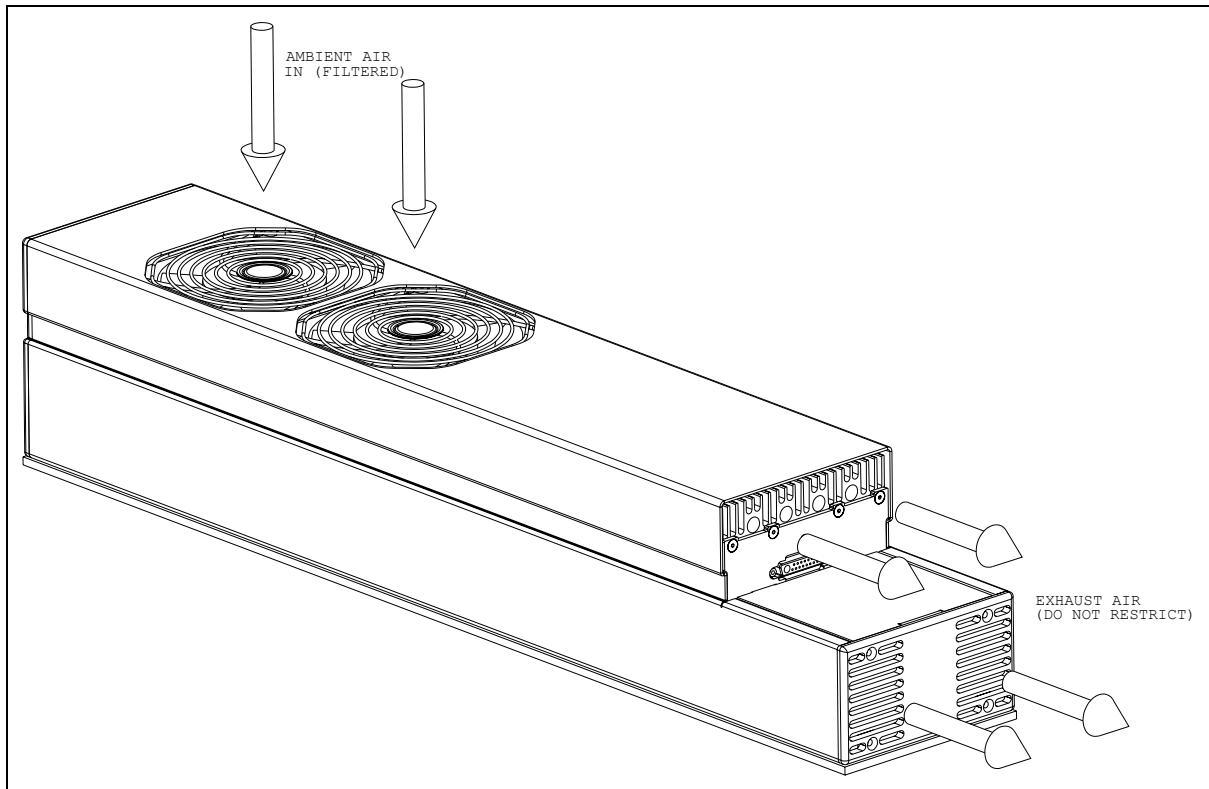

Figure 6 – Detail of air flow through the laser

Finally, ambient air should be filtered before entering the laser to prevent a build up of dust and debris on the cooling fins which can reduce cooling efficiency, however, care should be taken when selecting a filter media to ensure that the filter does not restrict air flow. For relatively clean environments a low restriction filter media (45 pores per inch for example) might be adequate but for dirtier environments a heavier filter media might be required and in this case a booster fan can be employed on the exhaust end to help pull air through the laser.

6.2 Ambient temperature

Air cooled lasers by nature are sensitive to ambient temperatures. Hotter ambient temperatures will reduce power output and cooler ambient temperatures will increase power output. An ambient temperature range of 50-95 °F [10-35°C] should be observed to guarantee proper laser operation. At temperatures below 50 °F [10 °C] operation may be intermittent and there is a potential for damage to the power supply and optics. At temperatures above 95 °F [35 °C] ULS lasers are not guaranteed to provide the rated power output. Lasers can safely be operated at ambient temperatures above 95 °F [35 °C] however power output will diminish as ambient temperature rises and longevity can be significantly reduced.

7.0 Water Cooling

7.1 Water Connections

ULS water cooled lasers are equipped with two “Instant Tube Fittings” for 3/8” OD tubing. Attempting to connect metric tubing directly to these fittings will result in leakage. To connect tubing to this fitting, make sure the tubing is squarely cut and push the tubing into the fitting until it stops (.8” - .9” insertion), then pull the tubing to ensure it is locked. Connect the OUT on the coolant source to the IN on the laser and the OUT on the laser to the IN on the coolant source (Please refer to Figure 1).

To remove the tubing from the fitting, push the orange plastic ring towards the fitting. Hold the ring in while pulling the tubing out. To ensure a good connection, we recommend that after removing tubing from a fitting, the tubing be trimmed 1” from the end so that un-inserted length of tubing is re-inserted into the fitting.

Take care to not kink the tubing as this will restrict coolant flow and can weaken the tubing.

Note: ULS water cooled lasers are shipped with plugs in the water fittings. Remove these prior to installation of tubing.

7.2 Coolant

ULS lasers are designed to be used with distilled water. Do not use de-ionized water.

Glycol-based coolants or additives are not necessary for use in ULS water cooled lasers as the lasers should not be operated below 50°F [10°C]. If the laser is connected to a closed-loop system, ULS recommends adding an algaecide/anti-corrosive such as Optishield Plus to the coolant. Do not exceed a coolant pressure of 60psi.

7.3 Environmental

The environment that ULS Water Cooled lasers operate in can affect their longevity and operation. Condensation forming on the laser can cause damage to optics and electronics, degrading performance or causing laser failure. Therefore it is important to set the coolant temperature properly.

The temperature at which airborne water vapor will condense on a surface is the dew-point. The dew-point is determined by air temperature and relative humidity. If the laser is cooled at or below the dew-point, condensation will form on the laser. The table below shows dew-point values for various temperature and relative-humidity values.

		Relative Humidity								
		10%	20%	30%	40%	50%	60%	70%	80%	90%
AIR TEMP	10°C	-20.2	-11.9	-6.8	-3.0	0.1	2.6	4.8	6.7	8.4
	15°C	-16.4	-7.8	-2.4	1.5	4.7	7.3	9.6	11.6	13.4
	20°C	-12.5	-3.6	1.9	6.0	9.3	12.0	14.4	16.4	18.3
	25°C	-8.7	0.5	6.2	10.4	13.8	16.7	19.1	21.3	23.2
	30°C	-4.9	4.6	10.5	14.9	18.4	21.4	23.9	26.2	28.2
	35°C	-1.2	8.7	14.8	19.4	23.0	26.0	28.7	31.0	33.1

The orange values are the dew point temperatures (in °C). For example, at an ambient temperature of 25°C with 40% Relative Humidity, the dew-point temperature is 10.4°C. The coolant temperature should be kept above this dew-point temperature to avoid condensation on the laser.

7.4 Chiller Capacity

The table below lists the minimum chiller cooling capacity requirements for ULR Water cooled lasers. We recommend a minimum of 2 gallons per minute flow rate.

ULS MODEL	MINIMUM CHILLER COOLING CAPACITY
ULR-25 / ULR-30	600W
ULR-40	850W
ULR-50 / ULR-60	1100W
ULR-75	1200W

7.5 Draining the Laser

When shipping a Water Cooled ULS tube, you must ensure that the laser is free of coolant. During shipping, temperatures can reach below freezing. If coolant freezes inside the laser tube, catastrophic damage can occur. To drain the tube, first insert short pieces of tubing into each water fitting, placing the ends of the tubes in a suitable reservoir or drain. Place the laser on a clean, water-resistant surface, so that the water fittings are nearest to the surface it is resting on. Allow the tube to drain completely. After draining, insert the plugs that the laser was shipped with into the water fittings.

8.0 Laser Troubleshooting Guide

(Rev 1.0 October 19th, 2006)

Use the following chart to troubleshoot the laser

SYMPTOM	PROBABLE CAUSE
1. Laser emission LED does not turn on	<p>a. Check the following:</p> <ul style="list-style-type: none"> i. Power is turned on to the laser ii. Interlocks are closed iii. Shutter jumper is on <p>If all of the above items are correct and the emission light still does not turn on then go to step (b)</p> <p>b. Measure the signal voltage on PIN7 with respect to PIN12:</p> <ul style="list-style-type: none"> i. If it reads 4.5V or greater then call the factory. Either the emission ready LED has malfunctioned or the RF electronics has malfunctioned. Please call the factory for further trouble shooting guidance. ii. If it reads lower than 1V then go to step (c). <p>c. Measure the signal voltage on PIN15 with respect to PIN12:</p> <ul style="list-style-type: none"> i. If it reads 4.5V or greater then call the factory for further trouble shooting guidance. <p>If it reads lower than 1V then the laser has encountered a temperature error. When the laser encounters a temperature error it will normally reset it self when its temperature falls within the operating limits. The laser can be brought to within its operating limits if the ambient temperature is held between 15 Celsius and 45 Celsius. If the laser has been at the rated ambient temperature for an hour and if the emission LED does not turn on go to step call the factory.</p>

<p>2. Laser emission LED is on but the laser does not fire</p>	<p>a. Check if your modulation signal is connected to PIN4 and the signal return is connected to PIN3.</p> <ul style="list-style-type: none"> i. If your connections are correct then go to step (b). <p>b. Disconnect the interlocks.</p> <ul style="list-style-type: none"> i. Is the emission LED on? If it is then you have a shorted Power FET. Please call the factory to rectify your situation. ii. Else go to step (c). <p>c. The laser's control electronics is emission ready, but it may or may not be gating the modulation signal through to the laser.</p> <ul style="list-style-type: none"> i. Please call the factory for resolving your problem.
<p>3. Fan does not turn on</p>	<p>a. Check the following:</p> <ul style="list-style-type: none"> i. Power is turned on to the laser ii. Fan connector is plugged into J7 <p>If this does not resolve your problem call the factory.</p>
<p>4. The laser stopped emitting even though the modulation signal is on</p>	<p>a. Is the emission LED on?</p> <ul style="list-style-type: none"> i. If it is off, then the laser detected a fault. ii. Else go to step (b) <p>b. If the emission LED is on then the laser's control electronics is emission ready and the problem may lie in the modulation gating signal section. Please call the factory for further advice.</p>

9.0 Shipping Lasers Back for Repair or Refill

If a laser requires repair or a refill, a return authorization can be obtained through the ULS Service department. When shipping a laser back to ULS it is important to use the original shipping materials in order to avoid shipping damage. If you have lost or discarded the original shipping material and need new shipping materials the ULS service department will be happy to provide them. *Please see Section 7.4 Draining the Laser.*

10.0 Recycling



By placing the above symbol on our products and accessories Universal Laser Systems is indicating that we are committed to helping reduce the amount of waste electronics ending up in municipal landfills. Therefore Universal Laser Systems urges consumers to recycle this product and its accessories. Universal Laser Systems is equipped to recycle any of its electronic products and accessories and will assist our customers with their recycling options. To arrange for recycling of your ULS product or accessory, please contact Universal Laser Systems for more information.

APPENDIX A: UL-8 Laser Serial Communications Protocol

Revision 2.0

July 25, 2006

**UNIVERSAL LASER SYSTEMS INC
16008 N. 81ST Street
Scottsdale, Arizona 85260**

UL-8 OEM Laser Communications Protocol Revision 1.0

This document describes and defines the protocol to be used when communicating with Universal Laser Systems UL-8 series lasers. The protocol is implemented on top of an RS485 physical link and the initial release (Rev-5 firmware with Rev-B hardware) assumes a non-multi drop configuration. A master control will initiate queries and the laser (slave device) will respond to each query.

1 Protocol Format & Attributes

A packet based system is implemented for messages. All messages are sent and received in HEX format.

Packet Format:

BYTE #	Description
1	First byte is always 0x00
2	Packet length valid values 5-255
3	Destination Address. Master address = 1. All laser addresses are decimal 128. Address 0 is invalid.
4	Commands (see Section 2 for command definition)
5	Bytes 5-254 are adjustable payload size for data. Minimum number of bytes is 1 and maximum number of payload bytes is 251.
255	8 Bit checksum. Implemented by XOR all bytes except the checksum

Total Number of bytes in a packet = 255

2 Detail Definition of Commands

The protocol allows users to read a group of laser attributes or read individual attributes.

2.1 Register Mappings

Command (HEX)	Command description
0x0A	This is a group read command. Returns: Data 1 = firmware version (valid range 1-255) Data 2 = rated power of laser (valid range 10-200) Data 3 = laser status (status = 1, laser ok; status = 0, laser fault)
0x0B	This is a group read command. Returns: Data 1 = interlock state (status = 1, closed; status = 0, open) Data 2 = key state (status = 1, closed; status = 0, open) Data 3 = shutter state (status = 1, closed; status = 0, open) Data 4 = FET state (status = 1, RF okay; status = 0, RF fault)
0x80	Read laser status. laser OK = 1, laser fault = 0
0x81	Read interlock state. interlock closed = 1, interlocked open = 0
0x82	Read key state. Key closed = 1, key open = 0
0x83	Read FET state. FET OK = 1, FET failed = 0
0x84	Read firmware version number 1-255
0x85	Read rated power (valid range 10-200)

Command (HEX)	Command description
0x87	Read diode state. Diode on = 1; Diode off = 0;
0x8A	Read laser operation mode, class-4 = 0, OEM = 1
0x8B	Read shutter state. shutter closed = 1; shutter off = 0;
0x90	Read laser temperature (valid range 0C – 255C)
0x92	Read maximum temperature recorded by laser (valid range 0C-255C)
0x93	Read temperature over limit counter (valid range 1-255)

3 Communication Example

The host/master controller sends and receives messages from a slave.

Example 1: Group Read command = 0x0A

Sent Packet from Master: 00 05 80 0A 8F all values in hexadecimal
 0x00 = preamble byte
 0x05 = packet length
 0x80 = laser address
 0x0A = command
 0x8F = checksum (exclusive OR of all bytes except checksum)

Reply from Laser: 00 08 01 0A 05 1E 01 19

0x00 = preamble
 0x08 = packet length
 0x01 = master address all master addresses are decimal 1
 0x0A = command executed
 0x05 = firmware revision 5
 0x1E = rated laser power 30 watts
 0x01 = laser functioning as expected
 0x19 = check sum of packet (exclusive OR of all bytes except check sum)