

SECTION 3

System Operation

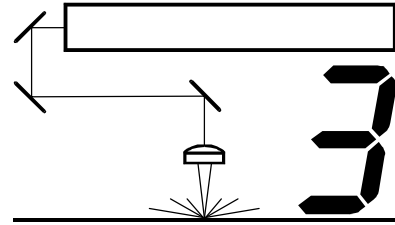

In this section you will learn how the laser system actually works and will familiarize you with laser system terminology. We will then start working with the control panel and learn how to get around in the menu system. Since there are many features in this laser system, the menu system may seem complicated at first, but once you start using it, you will find out that it is a very simple system to operate.

How it Works

There are five (5) basic components that make up a laser system, the control panel, the CPU, the DC power supply, the laser cartridge, and the motion system.

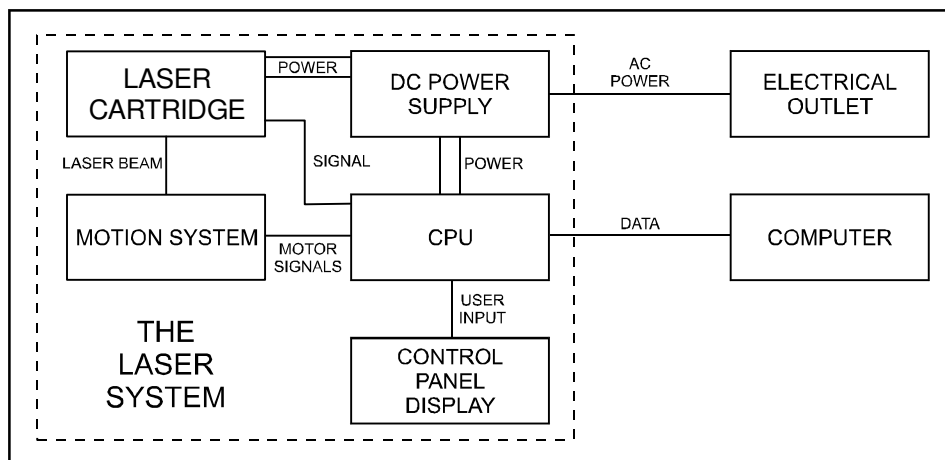

DC Power Supply

The DC power supply converts the incoming AC electricity to 48 volts DC. This is used to power both the laser cartridge and the CPU.

CPU

The CPU is the “brains” of the system and controls everything. Located on the CPU are standard computer memory SIMMS. This is where incoming files, from the computer, are stored while the power is on. The CPU gets input from the computer and the control panel. It outputs precisely timed signals to fire the laser beam and to move the motion system simultaneously.

Control Panel

This is where the operator controls the laser system. It is composed of tactile feel push buttons and a LCD display. From this panel, the operator can position the motion system, move around through the menu system in the LCD display, and run the laser system.

3-2 System Operation

Laser Cartridge

The laser cartridge is a very sophisticated device. It is composed of a plasma tube filled with a special mixture of CO₂ and other gases, and RF (radio frequency) electronics. The function of the entire assembly is to turn electrical energy into concentrated light energy. The word LASER is an acronym for Light Amplification by Stimulated Emission of Radiation.

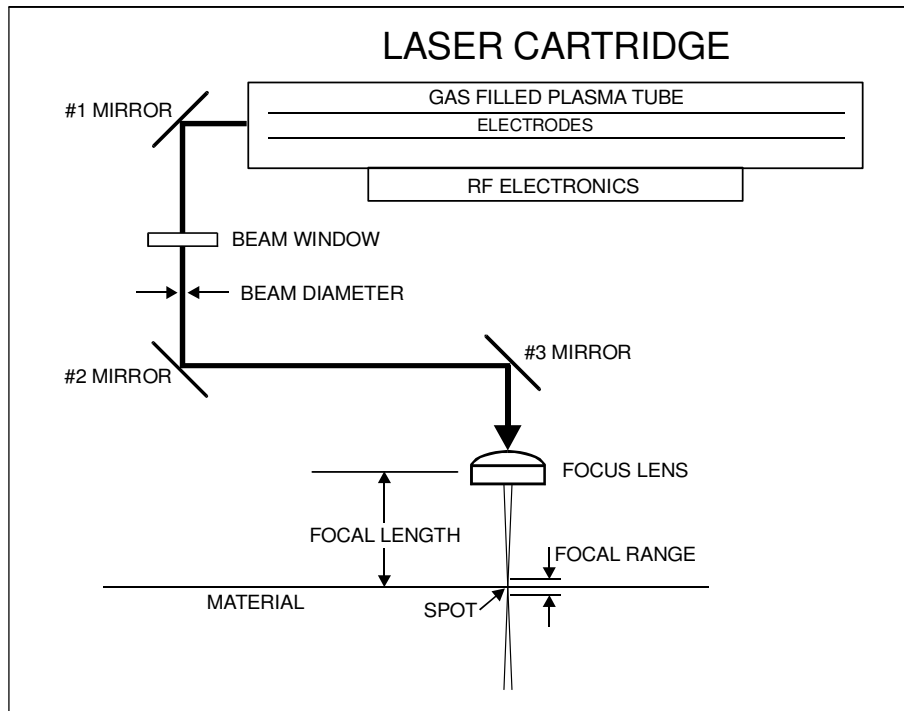

The laser cartridge receives power from the 48VDC power supply and its "trigger signal" from the CPU. When the laser system is power on and the trigger signal comes from the CPU, the RF electronics produce a 40 MHz signal across the electrodes located inside the plasma tube. This causes spontaneous photon emissions from the gas mixture that produces an invisible, infrared light beam at a frequency of 10.6 microns.

The laser beam exits the laser cartridge through its output optics, reflects off the #1 mirror, passes through the beam window, reflects off the #2 and #3 mirrors and then finally passes through the focus lens. The #2 and #3 mirror and the focusing lens are all mounted to the motion system. The width of the laser beam as it exits the tube, called the "Beam Diameter", is about 4 mm. The focus lens focuses the beam into a very small spot where the "Spot Size" is dependent on the "Focal Length" of the lens. The "Focal Length" is the distance from about the center of the lens to the point where the beam converges into the smallest spot possible. Using a standard 2 inch focal length lens, the spot size produced is approximately .005 inches.

The “Focal Range” of the lens, where the beam is considered to be “in focus”, is equivalent to +/- 5% above and below the focus point. Shorter lenses produce a smaller spot size but also have a very narrow focal range. This means that it would only be useful for engraving very flat objects. The longer lenses have a much wider range of focus but also produce a larger spot size that would prohibit the engraving of fine detail. This can be related to trying to write small text with a wide, felt tip marker. There are pros and cons to the different lenses that are available for different applications. Please refer to the Appendices section on available lenses and their operating characteristics.

“Wattage” signifies the amount of heat energy that the laser light is producing over a period of time. Laser energy is measured with a laser power meter that measures the unfocused laser beam’s heat output over a calibrated period of time.

Motion System

The motion system consists of the mechanically moving parts of the laser system. It is made up of rails, motors, bearings, belts, mirrors, a lens, and other parts. There are two directions of motion, left and right is called the “X” direction and front to back is called the “Y” direction.

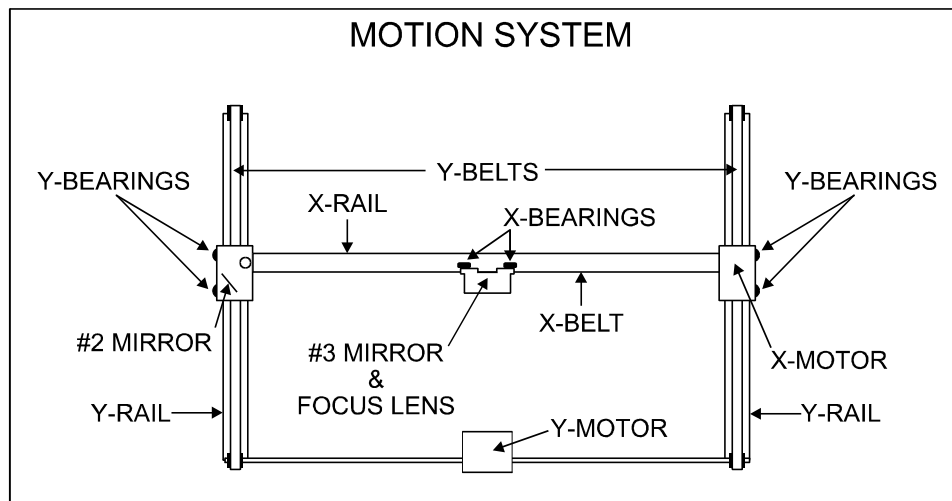

The CPU controls the movement of the motors, which moves the mirrors and focus lens across the engraving area and over the material. At the same time, it is synchronizing the laser pulses with the position of the focus lens. It is this precise positioning and timing of the laser pulses that produces the highest quality and fastest speed of engraving.

In summary, the five (5) components work together to take the graphic image that is downloaded to the laser system from your computer and burn it into the material located on the engraving table inside of the laser system.

The Control Panel

The control panel on the laser system provides easy access to all of the controls necessary for cutting and engraving operations. The control panel consists of a liquid crystal display (LCD), indicator lights, and selection buttons. The following section will describe, in detail, how to maneuver through the menu system and the significance of each item in the control panel.

3-4 System Operation

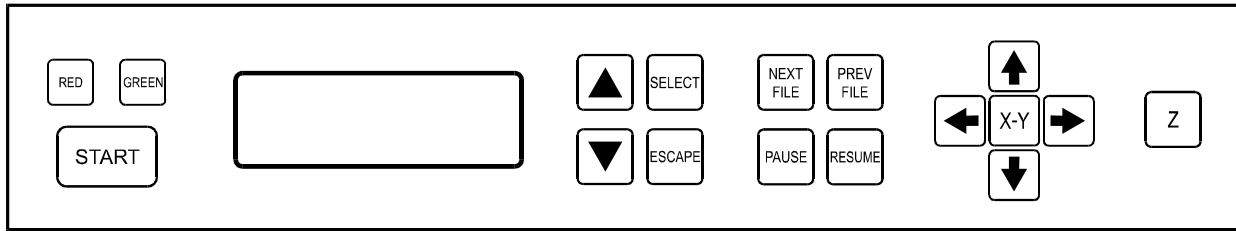

The Liquid Crystal Display (LCD)

The LCD is a four line display that displays the menus that control the laser system. It is a backlit type of display that enhances visibility even under low light environments.

When the laser system is powered on, the laser system will perform a series of routines. "INITIALIZING" will display until the motion system and electronics have finished their routines. When completed, the display will then read "READY", signifying that the laser system is ready to accept files.



DO NOT download files until the display reads "READY" as this can lead to an incorrect or corrupted file download. Corrupted file downloads can lead to an incorrect firing of the laser which can destroy the material you are engraving.



The two up and down arrow buttons to the right side the LCD give complete access to the menu control system. Use these arrow buttons to move the cursor up or down through the items in the display.



Both of these buttons each serves two purposes. Depending on which menu you are in at the time, the "SELECT" button either enters you into that menu item the cursor is currently on, or it toggles that menu item to display different choices. Some items in the display lead to other menus and some are settings that can be adjusted. The "ESCAPE" button, depending on which menu you are in at the time, either exits you back to the previous menu or it nullifies or cancels any changes that you have made to that menu item. Continuously pressing the "ESCAPE" button will eventually bring you back to the "MAIN" menu.



The indicator lights will act differently depending on the current state of the laser system. The chart below describes the conditions of the indicator lights during different modes of operation.

Green Indicator Light

CONDITION	REASON
ON	The laser system is powered up, the top door is closed and the system is ready to receive a file
	The laser system has finished processing a file and has returned to the home position
	The laser system has been paused while running a file
OFF	The top or front door is open
	The laser system is firing the beam in the Alignment Mode
FLASHING	The file is running

Red Indicator Light

CONDITION	REASON
ON	The laser system is initializing
	The laser system is firing the beam in the Alignment Mode
OFF	The laser system has finished initializing and is ready to receive a file
	The top or front door is closed
FLASHING	The top or front door is open

The Process Controls

These control the actual running of the laser system.



Runs the current file displayed in the "File Display" menu.



If a file is running, the "PAUSE" button halts the engraving or cutting process. When paused, the motion system arm will move to its home position in the upper right corner of the engraving area. When ready to continue operation, press the "RESUME" button and the system will begin cutting or engraving again exactly where it left off. If you wish to run the file from the beginning after pressing the "PAUSE" button, press the "START" button. **When "Curve Enhancement" mode is selected in the driver, the "Resume" button acts like the "Start" button and will start your file from the beginning.**

During slow raster or vector motions, the motion system might not pause immediately after the "PAUSE" button is pressed. It can take a few seconds or several seconds to stop the system because it needs to complete the motion commands that it is currently running. Opening the top door also works similar to the "PAUSE" button but not exactly. The first thing the laser system will do is turn off the laser beam immediately after the door is opened. The next thing it will do is pause the motion system. Since opening the door and the pausing of the motion system are not precisely synchronized if you do this, resuming the file might cause an area of missed engraving. Opening the door to turn off the laser and to pause the motion system should only be used for safety or emergency reasons.

3-6 System Operation

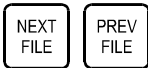

The “NEXT FILE” button displays the next file in the systems memory and makes it the current file and will stop at the last file in memory. The “PREV FILE” button displays the previous file in the systems memory and makes it the current file and will stop at the first file in memory. These buttons are inoperative if a file is currently running.

The Motion Control System

The motion control section of the control panel (the four directional arrow buttons) enables the user to manually control motion system movement.

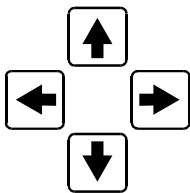

Pressing and holding down an arrow button will cause the focus lens assembly to move in the respective direction. The motion system starts off slowly, but if you continue to hold down the button, you will see it accelerate to a faster speed. Pushing the button once and letting it go quickly will move the motion system in .001 inch increments. Pressing two adjacent buttons will move the assembly in a diagonal direction. This part of the control panel is primarily used to position the focus lens assembly directly over the engraving material and to use the focus tool to set the proper focus height. Other uses for these buttons will be discussed later in this manual.



You must be in the “FILE DISPLAY” menu or the “MAIN” menu for this button to be operable. Pressing it enables the “ORIGIN POSITION” menu to appear. It also turns on the optional red laser diode that shows where the focus lens assembly is positioned in the field by shining a bright red “dot” on the engraving area. Further details on how to use this button will be covered later in this section.



This button positions the focus carriage slightly away from the upper left hand corner at the default (1,1) position in the engraving area. This is where the majority of focusing will be done. Once the focus carriage is positioned, using the motion control arrow buttons can still move the motion system. Pressing the button again will move the focus carriage back to the home position in the upper right corner of the engraving area. You can set the default position to anywhere in the field that you desire. Relocating the focus position is covered later on in this section.

...continued from previous page

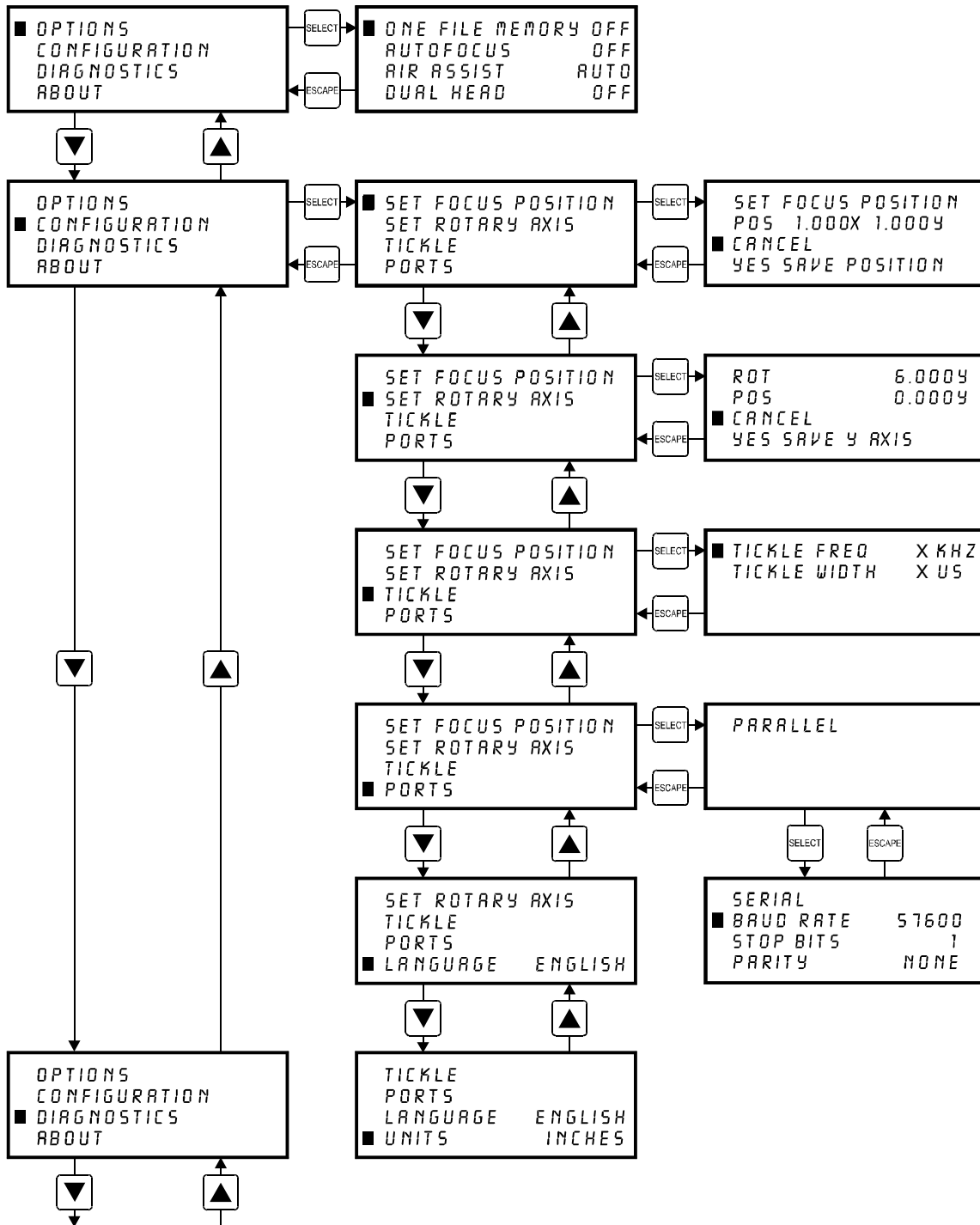

...continued on next page

...continued from previous page

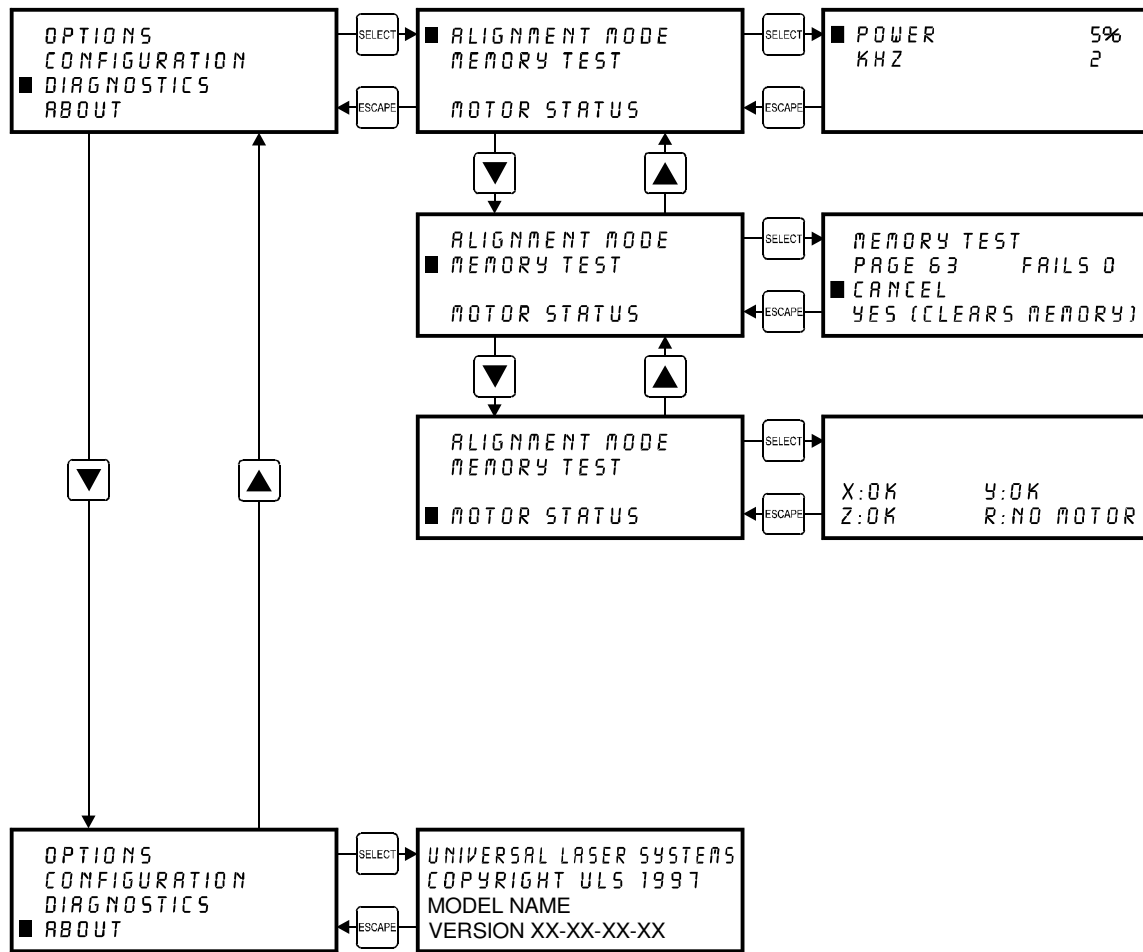

Menu Descriptions

The remainder of this section will describe each one of the menus and their significance.



READY Menu

When the system is first powered on "INITIALIZING" will appear for approximately 30 seconds until the laser system finishes performing its routine. When the system has finished initializing, "READY" will appear in the display, indicating that the laser system is ready to accept files.

3-10 System Operation

```
■001)FILENAME.XXX  
PUR 100% 0:00:00  
SPD 100% COPIES 0  
PPI 500 500 DPI
```

FILE DISPLAY Menu

Appears automatically after the first file is downloaded completely into the laser systems memory. This is the menu that you will remain in most of the time when operating the laser system. It has been designed to show all pertinent operating information at a glance so that constantly jumping from menu to menu is not needed.

The first line indicates the filename. If more than one job has been downloaded, you can move to the next file in memory by pressing the “NEXT FILE” button. You can page through the list of files available in memory by placing the cursor on the first line of this display and pressing the “SELECT” button which move the cursor to the right side of the display. The up and down arrow buttons can then be used to move through the list of files in memory. When the desired file is found, simply press the “SELECT” button to make that file the current file. This will move the cursor back to the left side of the display. To run the currently selected file, simply press the “START” button. Changing the current file is not possible while the laser system is running. For experimental purposes, Power, Speed, and PPI settings can be altered while the file is running allowing you to adjust these settings until the desired depth or effect is achieved. To do this, press the up or down arrow button until the cursor is on the desired item. Press the “SELECT” button, which moves the cursor to the right, and then use the arrow buttons to increase or decrease the values. Pressing the “SELECT” button again will accept the change but pressing the “ESCAPE” button nullify the change and restore it to the original setting. It is possible to adjust the settings while engraving on some scrap material until the desired “POWER”, “SPEED”, and “PPI” settings are obtained. Note these settings, change them in the driver and re-send the file to the laser system for the final run.

NOTE: Since the file has the settings stored in the beginning of the data, you must first start the file before you can change the settings. You can then either pause the file, change the settings, and then resume the file or you can change the settings on the fly while it is running. Remember, these are only temporary changes so if you pressed the “START” button to start the file over again, it will take on the original settings that you sent down from the driver.

The display contains a timer to time files as they are run (this is useful for job costing). The timer will pause when the “PAUSE” button is pressed and starts up again when cutting or engraving has been “RESUME”d. If the same file is run again, the timer will count backwards displaying how much time is remaining. The “COPIES” feature indicates the number of completed runs of the file that is displayed. The DPI section displays the DPI setting from the driver. The “TIMER”, “COPIES”, and “DPI” readouts are for display purposes only and cannot be altered.

Since the laser system is equipped with a unique way of storing multiple jobs in memory, special provisions are made to distinguish one job from the next. When using the printer driver, an end-of-file (EOF) marker is automatically sent to the laser system after each file is downloaded. An end-of-file marker is needed by the memory buffer in order for it to recognize the end of one file, the beginning of the next file, and to calculate the remaining free memory space. Without an EOF, the memory buffer will not operate properly.

There are two ways that a downloaded file will have a missing EOF. The first is if printing through the printer driver and printing is canceled, interrupted, or file size exceeds the remaining free memory space. If this occurs, chances are that the EOF never made it to the memory buffer and the memory buffer will show that it is empty or that the file does not exist. Part of the file might still remain in memory and might become mixed up with other files. This is why having the ability to insert an EOF marker from the control panel of the laser system is very important. In order to delete that partial file, the memory buffer must either be cleared entirely or an EOF must be manually inserted into the memory buffer. Inserting an EOF is the better choice here because the partial file can be deleted without disturbing the other files in memory. Secondly, when using DOS based programs, a printer driver other than the Windows printer driver must be used. DOS printer drivers do not know to send the required EOF to the laser system after file downloading. Again, the memory buffer will not recognize any file that exists if it does not have an EOF. In this case, an EOF must be manually entered into the memory buffer after each and every file download from a DOS based program. Since DOS printer drivers also do not send the name of the file within the file data, every file will be called "NONAME" once an EOF marker has been inserted. To distinguish one "NONAME" file from the next, the display will number the files in the order from which they were downloaded.

To insert an EOF marker in either case, position the cursor on the first line of the display where the filename is. Press and hold down the "NEXT FILE" button and then press the "SELECT" button at the same time. The word "NONAME" will appear if there is a partial file in memory or any DOS based file that does not have an EOF marker. What has happened is that the laser system searched for any file information that had entered into the memory buffer since the last completed file was downloaded. If it finds information, it scans to the end of the last bit of that information and inserts an EOF. The file then shows up on the display as "NONAME" and will allow either its solitary deletion without having to delete the other files in memory or it will allow the file to be run just as if it was downloaded from the Windows printer driver.

```

■ FILE DISPLAY
  MEMORY CONTROL
  DOS POWER SETTINGS
  PREFERENCES
    
```

MAIN Menu

Allows access to all other menus.

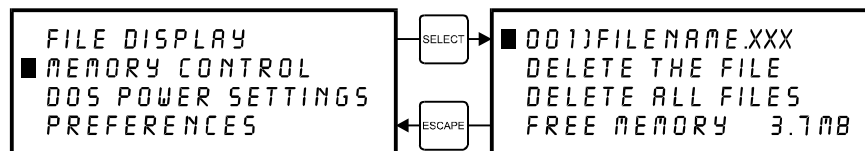

MEMORY CONTROL Menu

The laser system is equipped with an intelligent memory buffer that has built-in file compression. The amount of RAM installed in your system is optional at the time of purchase. The minimum is 4 Megabytes and the Maximum is 32 Megabytes.

3-12 System Operation

The Printer Driver compresses the file while it downloads to the laser system and the laser system decompresses the file while it runs. The amount of compression can be as little as 4 to 1 or as great as 48 to 1. This means that with 4 MB of RAM in the laser system, the buffer could hold the equivalent of 192MB worth of files provided they can be compressed 48 to 1. This gives the laser system the ability to store either larger or more files in memory. It also provides for quicker downloading because the files are much smaller than normal. The memory buffer can hold up to 999 files providing that the memory space is not exceeded. The memory also has built in file handling intelligence enabling each individual file in memory to be run in any order. The files are stored sequentially based on the order in which they were sent from the computer and each one is assigned a number to keep them in order. A running total of the free memory space available is provided at the bottom of the display. The file name displayed is always the currently active file and there are two methods for looking through the list of files to choose another one. The first method is to press the "NEXT FILE" button on the control panel. Each time the "NEXT FILE" button is pressed, the next file in memory becomes the current file. The second method is to move the screen cursor to the file name line and press the "SELECT" button to move the cursor to the right side of the display. Then, use the up and down arrow buttons to move backward or forward through the list until the file desired is displayed. Now, press the "SELECT" button again to bring the cursor back over to the left side of the display.

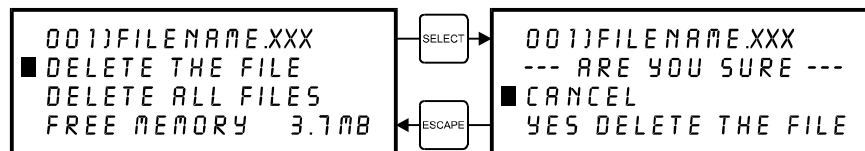

Eventually the memory will fill up with files that will need to be deleted to free up space for more files. It is possible to select each individual file and delete them one at a time. To accomplish this, make the desired file for deletion the current file in the same manner as previously described. Use the up or down arrow buttons to position the cursor on the "DELETE THE FILE" menu item and then press the "SELECT" button. The display will then ask if you are sure and will expect a "CANCEL" or a "YES" response. Use the up and down arrow keys to position the cursor on the appropriate choice and press the "SELECT" button.

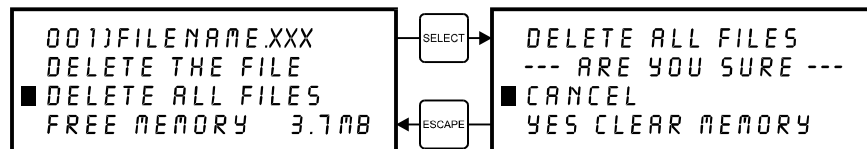

To completely clear out the entire memory buffer all at once, use the up and down arrow keys to position the cursor on the "DELETE ALL FILES" option and press the "SELECT" button. The laser system will again ask if you are sure so respond accordingly.



Deleted files cannot be undone. They must be re-downloaded if you accidentally delete them.

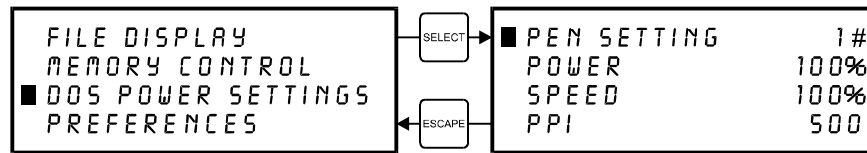

DOS POWER SETTINGS Menu

The laser system allows eight different power settings to be saved, in non-volatile (permanent) memory, and used when processing a DOS based file. Since DOS based printer/plotter drivers do not have the ability to set the “POWER”, “SPEED”, and “PPI” settings, the settings must be set manually on the laser system. Think of it as being able to assign laser “POWER”, “SPEED”, and “PPI” to the pen numbers of a flatbed plotter.

To access these settings, move the cursor to the “DOS POWER SETTINGS” menu and press the “SELECT” button. Press the “SELECT” button again to bring the cursor to the right side of the display where it sits on top of the pen numbers. Now use the up and down arrow buttons to scroll through settings 1 through 8. When the desired pen number is found, press the “SELECT” button again to bring the cursor over to the left side of the display. Bring the cursor down to the item you want to change, again press the “SELECT” button to bring the cursor to the right and use the arrow keys to adjust your settings. Remember, to accept the setting that you have made, press the “SELECT” button to bring the cursor back over to the left side of the display. Pressing the “ESCAPE” button nullifies your change. Once you have set the correct settings for all of the pen numbers that you will be using in your DOS software, press the “ESCAPE” button to bring you back to the “MAIN” menu. Your settings will be permanently stored just as long as you exit back to the “MAIN” menu before turning off the laser system. For more information on how to use DOS based programs with the laser system, please refer to the Appendices section in the back of this manual.

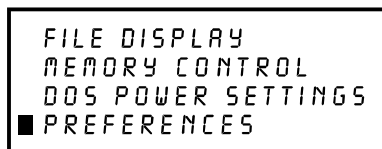

PREFERENCES Menu

The primary function of this menu is to allow access to other menus that can reconfigure the laser system. It also allows access to diagnostic and maintenance features. Selecting this option will lead to other menus of which some are adjustable and others that are display only.



Always escape back to the “MAIN” menu before turning off the laser system. This will permanently store your changes in non-volatile memory. If you turn off the laser system without escaping completely back to the “MAIN” menu then your changes would not have been stored and the system will revert back to its previous settings.

3-14 System Operation

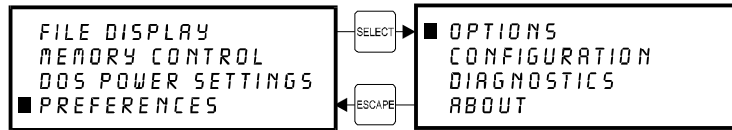

OPTIONS Menu

Selecting this menu will allow the access to turn on certain options that the laser system might have.

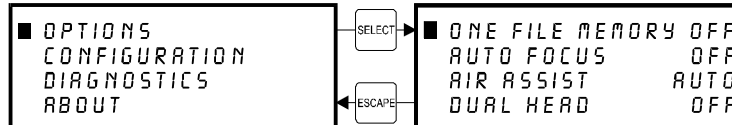

ONE FILE MEMORY Menu

Pressing “SELECT” key while cursor is on this line will toggle the setting on and off. When off, it enables the multiple file memory buffer system (default). When on, it disables the multiple file memory buffer and stores only one file at a time. How it works when it is turned on:

When you download a file to the laser system that file will appear in the “FILE DISPLAY” menu. Press the “START” key and run the file just as you would as if you were in the multiple file memory mode. You can run this file as many times as you want because it remains in memory.

Now, as you download the second file, observe the display and you will see “MEMORY EMPTY” flash momentarily and then the new file appears. Basically what has happened it that the laser system clears out the entire memory as the new file comes in to replace the first file. You can now run that second file as many times as you want. If you download another file, it dumps the entire memory again and the new file becomes the only file in memory, and so on.

While in this mode, the parallel port is turned off so no new files can be received until the file is finished running. This is to prevent the incoming file from erasing the file that is running.

Helpful Hint

You will notice that while in this mode of operation, all files downloaded will be labeled as the #1 file in memory. This might be confusing especially if you continuously download files with the same name. If you do this, you might question yourself whether or not you downloaded the next file because if you look on the display, it shows the same file number and the same name as the previous file that you ran. But if you look further, the timer will show 0:00:00 and the “COPIES” will be 0 if the file has never run. If the file did run, the “COPIES” will be greater than 0 and the time will show the amount of time that the file took to run.

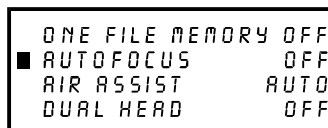

AUTOFOCUS Menu

Pressing the “SELECT” key while the cursor is on this line will toggle this option ON and OFF. Later in this section, we will explain how to use this option in more detail.

```

ONE FILE MEMORY OFF
AUTOFOCUS         OFF
■ AIR ASSIST       AUTO
DUAL HEAD         OFF
    
```

AIR ASSIST Menu

This class of laser system does have Air Assist as an option, but it is not computer controlled. Since we use the same menu system on other models, this menu selection for your model does absolutely nothing. If you did purchase the Air Assist option for this model, please refer to the instructions that came with that option.

```

ONE FILE MEMORY OFF
AUTOFOCUS         OFF
AIR ASSIST         AUTO
■ DUAL HEAD       OFF
    
```

DUAL HEAD Menu

This option is not available for this model of laser system.

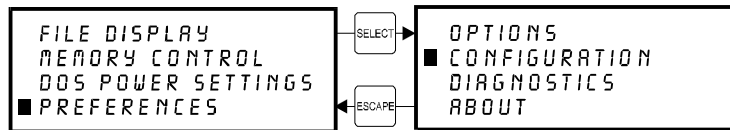

CONFIGURATION Menu

Selecting this menu will allow the reconfiguration of certain features of the engraving system and will lead to other menu items.

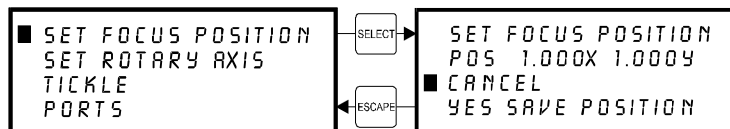

SET FOCUS POSITION Menu

This option allows you to set the focus position to anywhere in the field that you desire. Normally, the factory default setting for the “Z” button is (1,1). If you would like to change the factory default setting, go to this menu and press the “SELECT” button. If you have the optional red laser diode pointing device, the light will appear on the engraving table to assist you in determining the position desired.

Using the motion control arrow buttons to position the focus carriage assembly. While you are doing this can observe the coordinate display change as you move the focus carriage. These coordinates are the current position of the focus assembly in the engraving field. Once the desired position has been located, bring the cursor down to the “YES SAVE POSITION” line and press the “SELECT” button. Press the “ESCAPE” button twice to exit back to the “MAIN” menu. Your settings will automatically be retained permanently in memory.

3-16 System Operation

To restore the focus position back to the original factory setting, go back into this menu and press the up and down arrow keys simultaneously.



You will see the motion system move to the 1 inch horizontal and the 1 inch vertical position (factory default). Now select "YES, SAVE POSITION". Press the "ESCAPE" button twice to exit back to the "MAIN" menu. Your settings will automatically be retained permanently in memory.

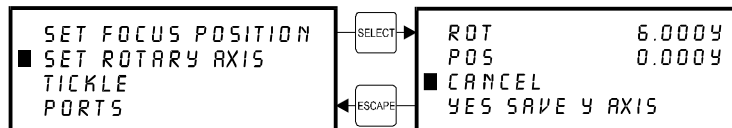

SET ROTARY AXIS Menu

The Rotary Fixture Axis is a setting that is pre-set at the factory. The laser system will sense when the Rotary Fixture is plugged in and will position the X-Axis arm directly over the centerline of rotation automatically when it begins to engrave. This setting can be altered if you position the Rotary Fixture in a location **OTHER** than the factory set position. Please refer to the section on the optional Rotary Fixture for a full description on how to set up and use this device before altering any factory setting.

To change the factory default setting, turn the laser system OFF, place the Rotary Fixture on the engraving table in the desired position, and **DO NOT** plug the Rotary Fixture into the electrical socket. Now turn the laser system on and with the motion system arrow buttons, position the X-Axis arm's focus lens carriage directly over the Rotary Fixtures centerline of rotation as the following diagram illustrates:

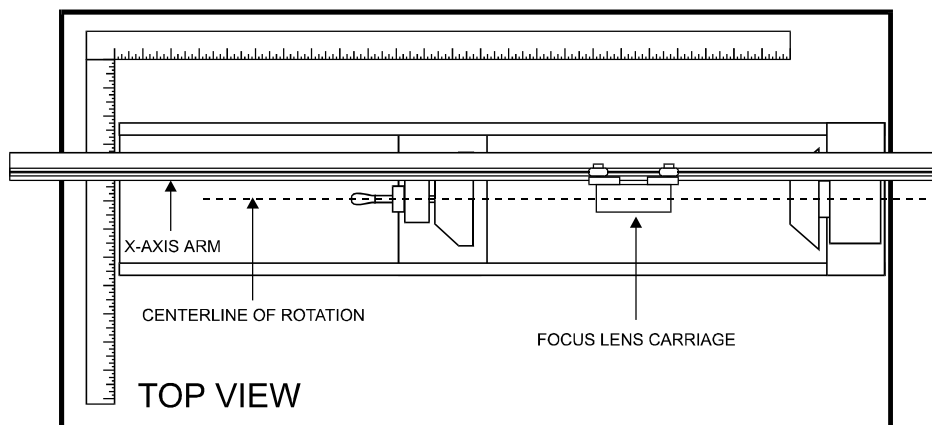

The left and right position (X-position) of the focus carriage is irrelevant in this setting and is not shown in the display. Now select the "YES SAVE Y AXIS" choice. If you change your mind and do not wish to alter the "ROTARY AXIS" position, select "CANCEL" instead and the original settings will be restored. Remember, always escape back to the "MAIN" menu before turning the system off so that your settings will be permanently stored in memory.



If you would like to get the Rotary axis back to the original factory default setting, go back into the “SET ROTARY AXIS” menu. While in this menu, press the up arrow and down arrow keys simultaneously. The arm move will move back to its original factory default setting. Select “YES SAVE Y-AXIS”, and then press the “ESCAPE” key twice to exit back to the “MAIN” menu to store this setting permanently.

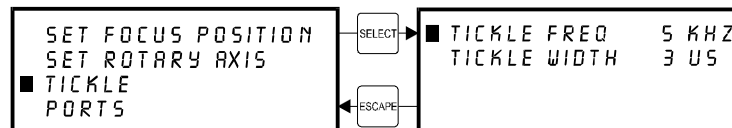

TICKLE Menu

TICKLE is the term used for small pulses, which are fed to the laser to keep the plasma inside energized. This allows the laser to respond quickly and strongly for high speed cutting and engraving.

TICKLE keeps the laser "warmed up" at times when the laser system is powered on but not firing and the top door is closed. We suggest keeping the door closed at all times when the laser system is powered on as this keeps the laser warmed up. If the door is open, the power to the laser cartridge itself is turned off and the tube will cool down. The laser runs best after being warmed up for 15 to 20 minutes.

TICKLE is pre-set at the factory and usually does not require adjustment. The setting shown above is only an example. Your laser platform may have a built-in Tickle setting control inside the laser cartridge. If your laser cartridge has built-in Tickle, then the setting in the control panel will read "Tickle Freq. = 5 kHz" and "Tickle Width = 0 us". If your laser cartridge does not have built-in Tickle, then you will see a "Tickle Width" greater than "0 us" and the "Tickle Freq." That can be anything from "2Khz" up to "10 kHz". However, it is possible that it may need adjustment after the laser cartridge ages. DO NOT attempt to adjust the TICKLE setting. Please contact our Service Department for the correct diagnosis and corrective procedure.

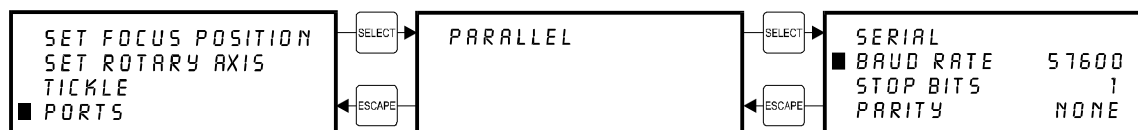

PORTS Menu

Two ports are provided on the back of the system for interface with a computer, a serial and a parallel port. Only one port can be used at a time. To activate a port, use the up and down arrow keys to position the cursor on the menu item “PORTS” and press the “SELECT” button. The menu that appears indicates the currently active port on the laser system. To toggle between ports press the “SELECT” button.

3-18 System Operation

In order to use the "SERIAL" port, the communication settings **MUST** match those of the computer. Refer to the computer's hardware and software manuals for details on setting up the computer's serial port. If using the "SERIAL" port, select the fastest possible "BAUD" rate for communication since this effects how quickly the computer can send files to the laser system. For "BAUD" rates of "9600" and above, set the number of "STOP BITS" on the computer to a higher value than the number of "STOP BITS" selected on the laser system. For example if the number of "STOP BITS" on the laser system is set to "1", then set the computer's stop bits to "1.5" or "2".

"PARITY" of the laser system and the computer **MUST** match exactly and the choices are "ODD", "EVEN", or "NONE". Pressing the "SELECT" button while the cursor is on "PARITY" will toggle through these choices.

Helpful Hint

Since the serial port works much harder than the parallel port does, it uses much more of the laser systems computer processors power to take in the files. Since this is the case, it is **NOT** recommended that you download a file while the laser system is running a different file. This can cause data corruption to occur to the file coming in to the computer. Either pause the laser system or wait until it finishes engraving the file before downloading the next one. This situation is for the serial port only. Disregard this warning message if you are using the parallel port for communications. The fastest method of file transmission to the laser system is the parallel port. Its use is highly recommended.

```
SET ROTARY AXIS
TICKLE
PORTS
■ LANGUAGE    ENGLISH
```

LANGUAGE Menu

Use the "SELECT" button to toggle through many different language choices. When the desired language is displayed, press the "ESCAPE" button twice to exit back to the "MAIN" menu. Your settings will automatically be stored permanently in memory. When the cursor is on this menu item, continuously pressing the "SELECT" button will toggle the languages in a loop fashion and will always bring you back to the original language.

```
TICKLE
PORTS
LANGUAGE    ENGLISH
■ UNITS     INCHES
```

UNITS Menu

Use the "SELECT" button to toggle between "INCHES" and "METRIC" units. Once the desired unit is displayed, press the "ESCAPE" key twice to exit back to the "MAIN" menu. Your settings will automatically be retained permanently in memory. When the cursor is on this menu item, continuously pressing the "SELECT" button will toggle the units in a loop fashion and will always bring you back to the original units.

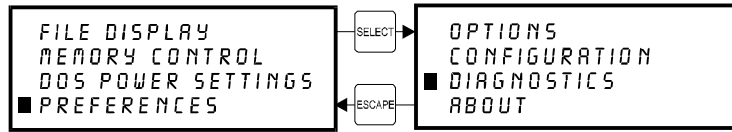

DIAGNOSTICS Menu

This menu leads to other menus that enable you to help diagnose problems, if they occur, with the laser system. It also will help our technicians solve problems that you may be experiencing.

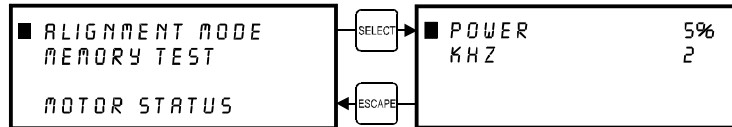

ALIGNMENT MODE Menu

This menu allows access to firing the laser beam manually to determine if the laser systems optical alignment is correct. The factory setting is a very low power setting that is just strong enough to check the laser beam alignment. Please refer to the maintenance section on how to safely check the laser systems beam alignment.

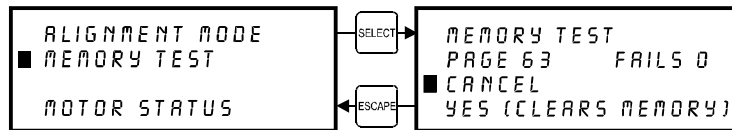

MEMORY TEST Menu

It may be necessary to use the diagnostic tests if instructed to do so by a member of our technical support staff. The “MEMORY TEST” is a memory buffer test to test the RAM in the laser system. This is very similar to the RAM test that your computer performs when it first gets powered on. In the process of testing memory, all files in memory will be erased. Once the “MEMORY TEST” is started it will continue to run until it is canceled. To start the test select “YES (CLEARS MEMORY)”. To end the test, select “CANCEL”. This test will continuously pass through the memory. If you are going to run this test, start it and let it run for about 10 minutes. If it finds memory that is bad, it will show up as a number other than a “0” in the fails column and the SIMM module will need to be replaced. Please contact technical support if there is a problem with the memory.

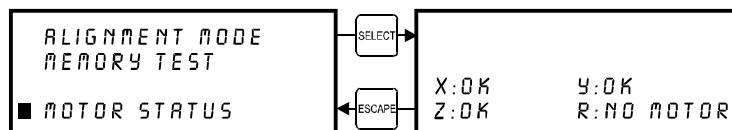

MOTOR STATUS Display

The last two lines of this display show the conditions of the stepper motors in the motion system. If there is a problem there will be an error message displayed next to the troubled motor. If the motor is completely disconnected, “NO MOTOR” will show in the display.

3-20 System Operation

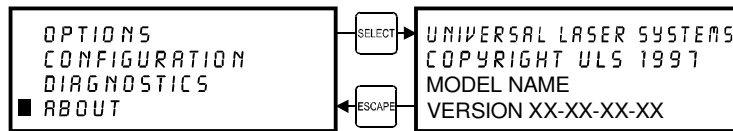

ABOUT Menu

Use the up and down arrow buttons to position the cursor on this menu item. Press the “SELECT” button and our copyright notice along with the current versions of firmware will be displayed. The firmware version numbers are a diagnostic aid to our service technicians. If you are having a problem with the laser system, a technician might ask you to read out the numbers in this display.

To access the following menus, the cursor must be located either in the “MAIN” or the “FILE DISPLAY” menus. They are not accessible if the cursor is in the “DOS POWER SETTINGS” or the “PREFERENCES” menus.

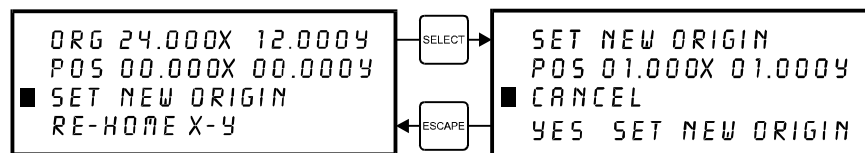

ORIGIN POSITION Menu

The laser systems default origin position is in the upper left hand corner of the engraving area at the (0,0) position of the rulers. You can, however, position the origin to any other point in the engraving area. To do this you must first get into this menu. From either the “MAIN” menu or the “FILE DISPLAY” menu, press the “X,Y” button in the middle of the four motion system directional arrow buttons.

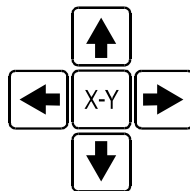

The red laser diode will appear on the engraving table. Using the directional arrow buttons, position the red dot at the location you would like to store as the new origin position. If you tap the motion control buttons, you will observe the motion system move at .001 inch increments. The longer that you hold down the button, the faster it moves. You can use either the digital display or the red dot as a reference for the new origin. When you have moved the red dot to the correct position, bring the cursor down to the “SET NEW ORIGIN” menu item and press the “SELECT” button. If you are sure with this position, move the cursor down to “YES, SET NEW ORIGIN” and press “SELECT” again. Escape out of the menu and your settings will be saved permanently in memory.



Setting a new origin other than the default (0,0) position will shrink your field size. If you already have files already loaded into memory that utilize the entire engraving area, and you set a new origin, part of that graphic might fall out of the effective printing area. If you run this file, unexpected results can occur that might destroy your material in the engraving area. We suggest that you use this feature cautiously and make sure that you do not set a new origin that would cause you graphic to print off the engraving area.

If you would like to reset the origin back to the original factory settings of (0,0) in the upper left corner, a quick way to get the motion system back to the upper left corner is to simply press the up arrow and down arrow keys simultaneously while in this menu.



You will see the carriage move to the upper left hand corner automatically. Again, select “SET NEW ORIGIN”, then select “YES, SET NEW ORIGIN” and your settings will automatically be stored in memory permanently.

Focusing the Laser Beam

To properly focus the laser beam onto the surface of the material, you need to perform two tasks. First position the focus carriage directly above the material and then use the focusing tool or the digital display to adjust the Z axis table level until the material is at the proper distance away from the focus lens.

Place your material into the upper left corner of the engraving field against the rulers. From either the “MAIN” or FILE DISPLAY” menus, press the “Z” button located on the control panel.



You will observe the focus carriage move to a pre-set focusing position of (1,1). The display will now show the “CURRENT LENS” that you are using and the current vertical “Z POSITION” of the engraving table.

3-22 System Operation

```
Z POSITION    0.00
CURRENT LENS 2.0
SET FOCAL LENGTH
RE-HOME Z
```

The cursor in the display will be flashing on top of the tenths digit. You can now move the table up or down by pressing either the up or down arrow button. If you push the button once and let go quickly, the table will move in .1 inch increments. If you hold down the button, it will move fluidly. To make finer moves, press the "SELECT" button to bring the cursor over to the hundredths digit. Pressing the up or down arrow button once and letting go quickly will move the table in .01 inch increments. Holding down the button will make it move fluidly. Practice moving the table up and down to get the feel of it before you attempt to focus on a material. We will explain the significance of the numbers in the display a little later on but for right now, press the "Z" button to bring the focus carriage back into the home position.

Essentially, there are three ways to focus on your material. One is to use the focus tool, another is to enter in the thickness of the material, and the other is to use AUTOFOCUS.

The Focus Tool Method

Place your material onto the engraving table. Visually make sure that the height of the material will not interfere with the focus carriage when you move it over the material to set focus. Press the "Z" button and observe the focus carriage move to the (1",1") position in the engraving area. If this is not a good focus position for you, use the motion system directional arrow buttons to position the focus carriage directly over your material. Use the up or down arrow buttons to move the table so that the flat side of the tool can sit flat up against the side of the focus carriage. Slowly raise the table until you observe the tool either tilting or sliding away from the focus carriage. This will occur when the bottom edge of the focus carriage meets with the top of the beveled edge of the focus tool. The objective is to stop the table at the point where the tool just starts to move or tilt.

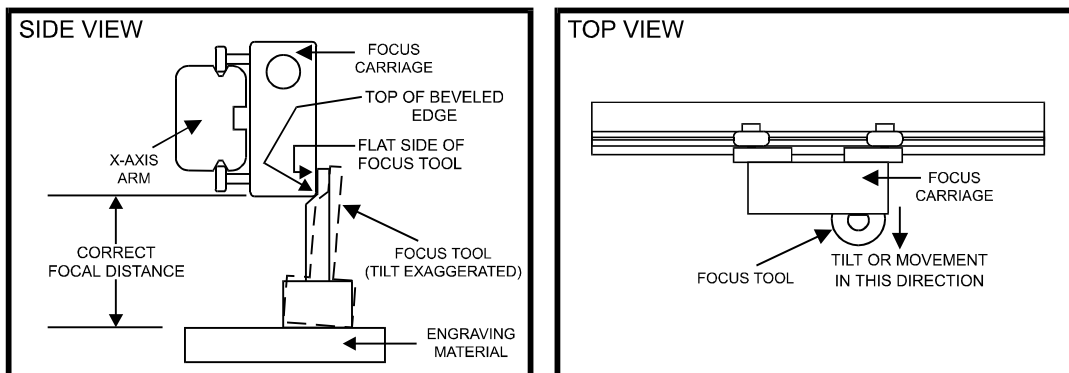

Remember, having the cursor, in the display, located on the tenths digit will move the table quickly and having it on the hundredths digit will move it more slowly. After focus has been established, remove the focus tool and press the "Z" button to move the focus carriage back into the home position.

If you find that you need to place your materials in a position other than the upper left hand corner, you can change the default focus position to anywhere in the field that you like. Please refer to that menu item selection earlier in this section.

The Material Thickness (Z POSITION) Method

The second method is to enter in the thickness of the material into the “Z POSITION” display. This method does not involve the use of the focus tool. For example, using a caliper or some other thickness measuring device, measure the thickness of your material and enter that thickness into the “Z POSITION” display. For example, if your material is 1 inch thick, use the up or down arrow button to raise or lower the table until the digital display reads “1.00”. That is all you need to do. Now press the “Z” button again to bring the motion system back to the home position. The beam is now precisely focused on the surface of your material. Think of it as using an imaginary focus tool.

The laser system table has been set up at the factory to read “0.00” when the beam is focused to the surface of the table when the lens that is installed on the focus carriage matches the “CURRENT LENS” in the display.

The factory has only set the “0.00” point for the lenses that you purchased at the time the system was shipped. If you purchase additional lenses, you will need to set the “0.00” point, also called the “FOCAL HEIGHT”, for each lens.

CURRENT LENS Menu

There are 4 lenses available, 1.5, 2.0, 2.5, and 4.0 inch lenses. All of them have different focal lengths so this is why we need to have a different “FOCAL HEIGHT” position for each lens. If you press the “SELECT” button while the cursor is on this menu item, you will see the right side of the display toggle into the different lens heights. You will also notice that the “Z POSITION” display change to reflect the difference in focal lengths. If you have purchased all of the other optional lenses with the laser system, all of the focal lengths have been set for you. If you just purchased the standard 2.0 lens, only that “FOCAL HEIGHT” was set at the factory. This is due to the fact that all lenses have slightly different focal lengths even if they are both 2.0 inch lenses so each one’s “FOCAL HEIGHT” must be calibrated on the machine.

SET FOCAL HEIGHT Menu

Use this selection to set the “0.00” for each lens. Using the focus tool that matches the “CURRENT LENS” displayed, position the table so that the laser will be focused on the table’s surface. If the display does not read “0.00”, move the cursor down to the “SET FOCAL HEIGHT” menu item and press the “SELECT” button. The display will ask “ARE YOU SURE?”. Move the cursor down to “YES” and press the “SELECT” button. The “Z POSITION” display will now read “0.00” and will be **PERMANENTLY STORED IN MEMORY** until you do this procedure again. If you have purchased other lenses, you can set each of their focal heights by making that lens the “CURRENT LENS” and repeating this procedure.

3-24 System Operation

The AUTOFOCUS Method

In order to use this method, you must first turn it ON. We described how to turn it ON earlier in this section. After you turn it ON, please follow the step by step instructions below.

To Use AUTOFOCUS:

- The AUTOFOCUS sensor sends out an invisible beam across the table between the 1 inch and the 3 inch mark in the Y axis ruler for the M-300 Platform and the 2 and 4 inch mark for the V-400, X-600 and X2-600 Platform laser systems. You will notice that it is indented slightly.
- Place your object between these two points vertically and anywhere on the table horizontally. Refer to the diagram below.

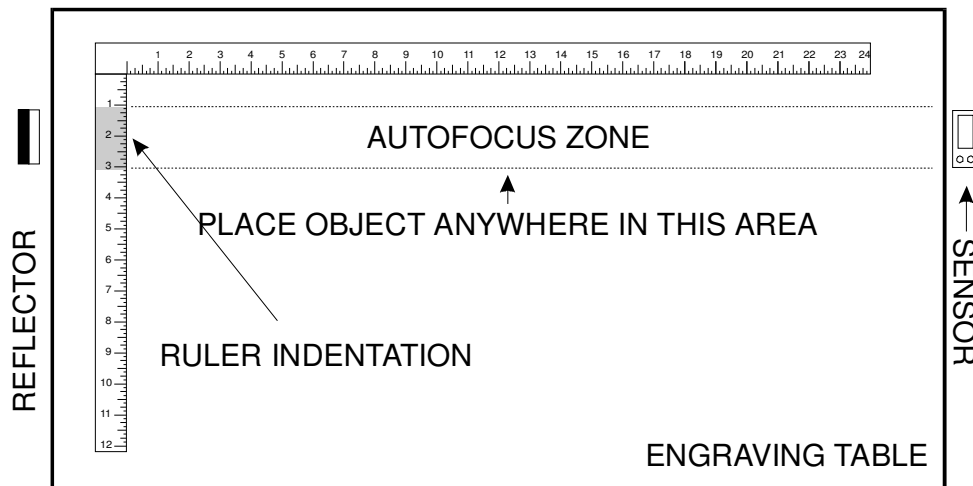

- Make sure that the laser system is in the main menu screen or the “File Display” menu. AUTOFOCUS will not work in the other menus.
- Press the “Z” button once on the control panel of the laser system. You will observe the Z-axis Table (Engraving Table) move down and then up again, adjusting the table to the proper focusing height. If the “Current Lens” choice in the menu system is not the same as the lens you have installed, correct it by placing the cursor on the second line of the display, and pressing the “Select” button to toggle you through your choices. Once the desired lens is displayed, escape out of the menu and AUTOFOCUS again. This will bring the table up to the correct height. The display will now show that the “Z Position” is “0.00” for that Focus Lens.
- If you desire to adjust the “Z Position” so that you are slightly out of focus, without exiting out of the menu, simply bring the cursor over to the “0.00” part of the display and adjust the table to the desired offset. The display will now show you how much you are out of focus. If you were to escape out of the display and perform the AUTOFOCUS procedure again, the “Z Position” will again show “0.00” to remind you that you are precisely in focus.
- If you have purchased additional lenses besides the 2.0 inch lens upon original delivery of the laser system, those other lens heights have been set at the factory. If you purchase additional lenses after you have received your machine and need to set the ‘Focal Height’ of that lens, or you need to adjust your AUTOFOCUS, please follow the next procedure.

To Adjust AUTOFOCUS:

From time to time, you may need to re-adjust your AUTOFOCUS. The only time that you should need to re-adjust the AUTOFOCUS is when you have received a new or different length Focus Lens, have recently Flash upgraded the operating system of the laser, or had a dirty sensor or reflector and are adjusting it after you have cleaned those parts.

- Place a very flat object on the Engraving Table, within the AUTOFOCUS Zone, that is at least 1 inch thick.
- AUTOFOCUS on this object by pressing the “Z” button once.
- While you are still in the “Z Position” display, move the Focus Carriage using the motion control keys so that it is above your object that you placed on the table.
- Place your Focus Tool on top of your object and compare the Focus Tool reading with the actual height that the AUTOFOCUS set the Engraving Table to. If it is not the same, bring the cursor up to the first line of the “Z Position” display and press the “Select” button. Now focus on your object by using your Focus Tool and adjusting the “Z Position” until you are manually focused on top of your object.
- Press the “Escape” button, move the cursor to the “Set Focal Length” line and press “Select”. It will ask you if you are sure so move the cursor down to the “YES” line and press “Select”. The AUTOFOCUS will now have been re-adjusted to be exactly at the same height as your Focus Tool. The purpose of “Setting the Focus Length” is to calibrate AUTOFOCUS with your Focus Tool so that whether you use AUTOFOCUS or use the Focus Tool, you will always be putting the Engraving Table at the correct focusing height.
- If you have purchased additional lenses, repeat this procedure for each lens by changing the “CURRENT LENS” on the display and your focus tool, to the one you are calibrating.

AUTOFOCUS Maintenance:

If the AUTOFOCUS reflector or sensor becomes dirty from engraving smoke, it may malfunction. A sign of AUTOFOCUS malfunction is upon activation, the table either moves all the way down to the bottom or all the way up to the top and will try to keep on moving until you power the machine off. If this did happen, you will need to clean your sensor and reflector and then perform the AUTOFOCUS adjustment procedure. An indication that the sensor and reflector are clean is that you will see a little green light appear on the side of the sensor. If you see both green and red lights, the sensor and/or reflector are dirty or blocked. **NOTE: Make sure that the table is down far enough so that the sensor “sees” the reflector before assuming that there is a problem.**

To clean, dampen a tissue with water and gently wipe across the sensor and reflector in one direction. Gently wipe again with a dry tissue.