

Wiring Harness Interlocks for MVX

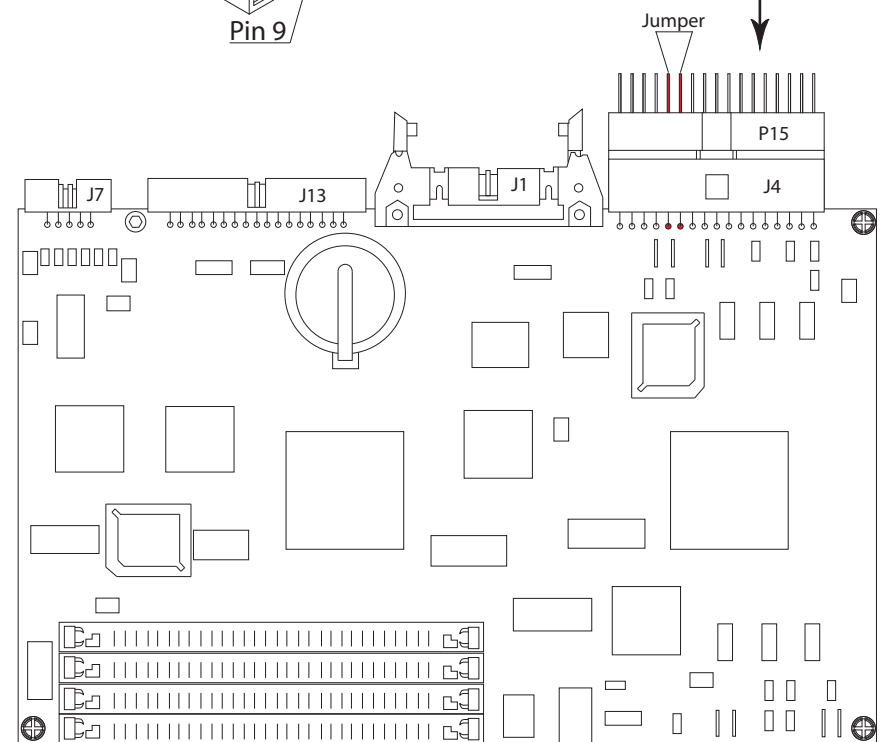
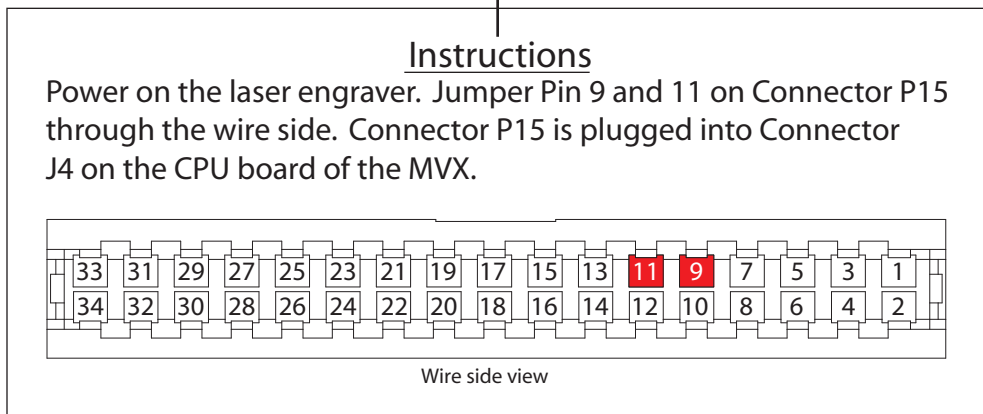
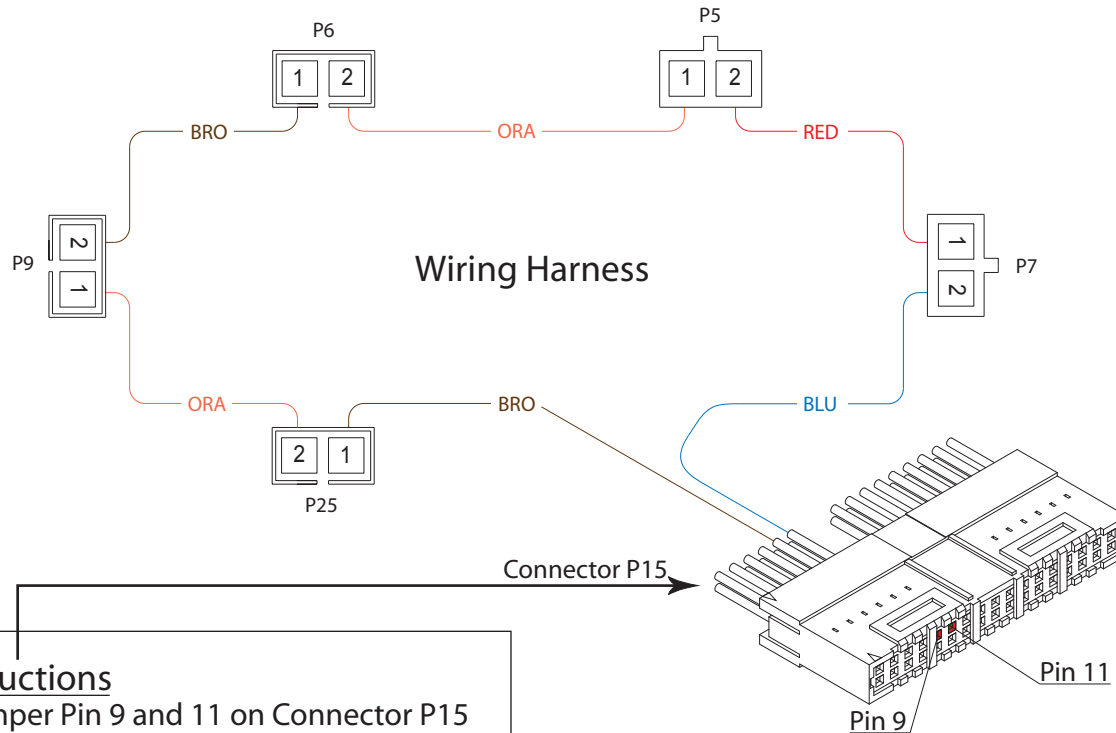
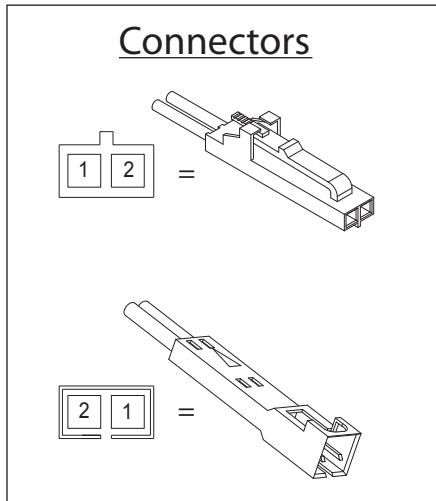

Connections

P15 (connector) pin 9	to	P25 (interlock-back cover) pin 1	brown
P25 (interlock-back cover) pin 2	to	P9 (interlock-front right) pin 1	orange
P9 (interlock-front right) pin 2	to	P6 (interlock-front left) pin 1	brown
P6 (interlock-front left) pin 2	to	P5 (interlock-top left) pin 1	orange
P5 (interlock-top left) pin 2	to	P7 (interlock-top right) pin 1	red
P7 (interlock-top right) pin 2	to	P15 (connector) pin 11	blue

Note: Not to scale

CPU Board