

REVISIONS			
REV	DATE	ECO	APP'D
A			
B	3/31/2005	1306	DD

ITEM NO.	QTY.	PART NUMBER	DESCRIPTION
1	1	700-0979-2	XL CARRIAGE OPTICS COVER
2	1	700-0977-0	XL #3 LENS HOLDER
3	1	700-0978-0	XL #3 MIRROR HOLDER-WIDE BEAM
4	1	268-0002(0003)-0	Ø.100 x .060 NdFeB MAGNET
5	4	500-2603-0	FPCS 2-56 x .188 SS (MMC-91771A076)
6	1	620-0018-0	MIRROR, Ø1.500\" X 1.000\" TRUNCATED
7	5	500-4206-0	SCS 4-40 x .375 SS
8	5	575-0001-0	#4 THUMB SCREW CAP (MMC-94052A021)
9	1	610-0029-0	Ø1.00 x 2.00 WD LENS
10	1	795-0043-0	2.0\" FOCUSING TOOL

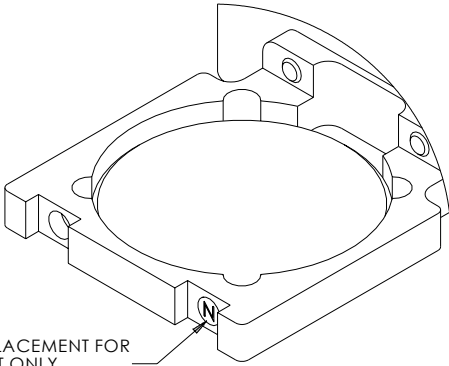

NOTE: MAGNET PLACEMENT FOR 2.0\" LENS KIT ONLY

DETAIL N
SCALE 3 : 1

APPROVALS		DATE	
DRAWN		12 OCT 2004	
CHECKED	SERVICE		
ENGINEERING	PRODUCTION		
PROPRIETARY NOTE			
THIS DRAWING AND ANY DATA DISCLOSED THEREIN IS THE PROPERTY OF UNIVERSAL LASER SYSTEMS, INC. AND CONSTITUTES AND CONTAINS PROPRIETARY AND CONFIDENTIAL INFORMATION. NEITHER RECEIPT NOR POSSESSION OF THIS DRAWING CONVEYS OR TRANSFERS ANY RIGHT TO DUPLICATE, USE, OR DISCLOSE ANY INFORMATION CONTAINED HEREIN EXCEPT AS EXPRESSLY AUTHORIZED BY UNIVERSAL LASER SYSTEMS, INC.			
SIZE	DRAWING NO.	REV	
B	145-0062-0	B	
DO NOT SCALE DRAWING	SCALE	N/A	SHEET 1 OF 1

Universal Laser Systems, Inc.

XL LENS KIT 2.0

SIZE: B DRAWING NO.: 145-0062-0 REV: B

DO NOT SCALE DRAWING SCALE: N/A SHEET 1 OF 1